

PG80MSAA/PG80MSLA



Scan here to learn more about this appliance and installation via a mobile device.

Scan here to access web-based literature, airflow tables, and troubleshooting guides.



THIS BOOKLET CONTAINS IMPORTANT INFORMATION

INSTALLER: USE THE INFORMATION IN THIS BOOKLET TO INSTALL THE APPLIANCE AND AFFIX THIS BOOKLET ADJACENT TO THE APPLIANCE AFTER INSTALLATION.

USER: KEEP THIS BOOKLET OF INFORMATION FOR FUTURE REFERENCE.

SERVICER: USE THE INFORMATION IN THIS BOOKLET TO SERVICE THE APPLIANCE AND AFFIX THE BOOKLET ADJACENT TO THE APPLIANCE AFTER SERVICING.

LITERATURE ASSEMBLY BOOKLET NO.: 348037-701

PG80MSAA

Cover Page P/N 348037-201

MODEL PG80MSLA



348037-701 REV.A



Printed on recycled paper.

NOTE TO INSTALLER: This manual must be left with the equipment owner.

A Carrier Company © 2021 Carrier. All rights reserved.

 **WARNING**

This product can expose you to chemicals including Lead and lead compounds, which are known to the State of California to cause cancer and birth defects or other reproductive harm. For more information go to www.P65Warnings.ca.gov

 **AVERTISSEMENT**

Ce produit peut vous exposer à des agents chimiques, y compris le plomb et les composés de plomb, identifiés par l'État de Californie comme pouvant causer le cancer et des malformations congénitales ou autres troubles de l'appareil reproducteur. Pour de plus amples informations, prière de consulter www.P65Warnings.ca.gov

 **ADVERTENCIA**

Este producto puede exponerlo a químicos que incluyen plomo y compuestos de plomo, los cuales son conocidos en el Estado de California como causantes de cáncer y defectos de nacimiento, u otros daños reproductivos. Para mayor información, visite www.P65Warnings.ca.gov

PG80MSA/PG80MSLA

80% AFUE, Single-Stage, Multi-Speed ECM,
4-Way Multipoise, Non-Condensing Gas Furnace

Installation, Start-Up, Operating and Service and Maintenance Instructions

NOTE: Read the entire instruction manual before starting the installation.

TABLE OF CONTENTS

| | |
|---|----|
| Table 1 – Dimensions | 2 |
| SAFETY CONSIDERATIONS | 3 |
| INTRODUCTION | 4 |
| ELECTROSTATIC DISCHARGE (ESD) PRECAUTIONS PROCEDURE | 5 |
| LOCATION | 6 |
| AIR FOR COMBUSTION AND VENTILATION | 7 |
| Table 2 – Minimum Free Area Required for Each Combustion Air Opening or Duct to Outdoors | 8 |
| Table 3 – Minimum Space Volumes for 100% Combustion, Ventilation, and Dilution from Indoors | 8 |
| INSTALLATION | 9 |
| Table 4 – Opening Dimensions - In. (mm) | 11 |
| FILTER ARRANGEMENT | 12 |
| AIR DUCTS | 12 |
| GAS PIPING | 13 |
| Table 5 – Maximum Capacity of Pipe* | 14 |
| ELECTRICAL CONNECTIONS | 15 |
| Table 6 – Electrical Data | 16 |
| VENTING | 18 |
| Table 7 – Combined Appliance Maximum Input Rating in Thousands of BTUh per Hour | 20 |
| Table 8 – Minimum Allowable Input Rating of Space-Heating Appliance in Thousands of BTUh per Hour | 20 |
| AIR DELIVERY - CFM | 24 |
| Table 9 – Air Delivery - CFM (with filter)* | 24 |
| Table 10 – Airflow Settings | 28 |
| FURNACE CONTROL PROGRAMMING AND NAVIGATION | 28 |
| Table 11 – System Status Display Codes | 29 |
| Table 12 – Main Menu Options | 29 |
| SERVICE LABEL | 30 |
| START-UP, ADJUSTMENT, AND SAFETY CHECK | 31 |
| Table 13 – Test Sequence | 31 |
| WIRING DIAGRAM | 32 |
| Table 14 – Altitude Derate Multiplier for U.S.A. | 33 |
| Table 15 – Gas Rate (Cu Ft./Hr.) | 34 |
| Table 16 – Orifice Size* and Manifold Pressure (in. w.c.) for Gas Input Rate | 34 |
| Table 17 – Orifice Size* And Manifold Pressure (in. w.c.) for Gas Input Rate | 35 |
| SERVICE AND MAINTENANCE PROCEDURES | 36 |
| CARE AND MAINTENANCE | 37 |
| Table 18 – Filter Size Information (In. / mm) | 38 |

| | |
|-------------------------------------|----|
| SEQUENCE OF OPERATION | 40 |
| TROUBLESHOOTING | 42 |
| PARTS REPLACEMENT INFORMATION GUIDE | 46 |
| MODEL NOMENCLATURE | 46 |

To learn more about this appliance and installation via a mobile device, go to <https://www.paync.com/NFC> or use the QR code below. To access airflow tables or troubleshooting guide on your mobile device go to mlctraining.com/training/techdocs/37/ or use the QR code below.



Mobile App QR Code



Airflow QR Code

A220930



Use of the AHRI Certified TM Mark indicates a manufacturer's participation in the program. For verification of certification for individual products, go to www.ahri/rectory.org.



A200103

WARNING

CARBON MONOXIDE POISONING HAZARD

Failure to follow this warning could result in personal injury and/or death.

Carbon Monoxide (CO) is a colorless, odorless, and tasteless poisonous gas that can be fatal when inhaled. Follow all installation, maintenance, and service instructions. See additional information below regarding the installation of a CO Alarm.

Most states in the USA and jurisdictions in Canada have laws that require the use of Carbon Monoxide (CO) alarms with fuel burning products. Examples of fuel burning products are furnaces, boilers, space heaters, generators, water heaters, stoves/ranges, clothes dryers, fireplaces, incinerators, automobiles, and other internal combustion engines. Even if there are no laws in your jurisdiction requiring a CO Alarm, it's highly recommended that whenever any fuel burning product is used in or around the home or business that the dwelling be equipped with a CO Alarm(s). The Consumer Product Safety Commission recommends the use of CO Alarm(s). The CO Alarm(s) must be installed, operated, and maintained according to the CO Alarm manufacturer's instructions. For more information about Carbon Monoxide, local laws, or to purchase a CO Alarm online, please visit the following website. <https://www.kidde.com>.

Portions of the text and tables are reprinted from current edition of NFPA 54/ANSI Z223.1E, with permission of National Fire Protection Association, Quincy, MA 02269 and American Gas Association, Washington DC 20001. This reprinted material is not the complete and official position of the NFPA or ANSI on the referenced subject, which is represented only by the standard in its entirety.

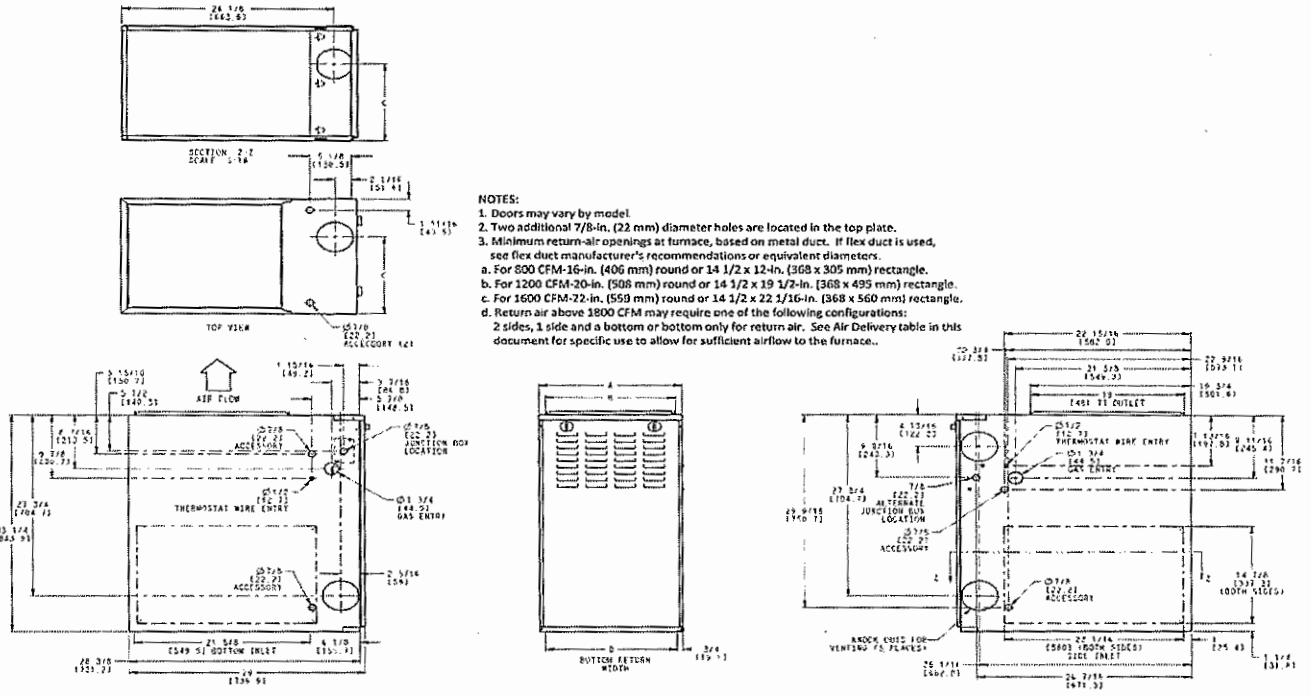

Fig. 1 – Dimensional Drawing

Table 1 – Dimensions

| Unit Size | A CABINET WIDTH | B OUTLET WIDTH | C TOP AND BOTTOM FLUE COLLAR | D BOTTOM INLET WIDTH | VENT CONNECTION SIZE | SHIP WT. LB. (KG) |
|-----------|--------------------|-------------------|---------------------------------------|----------------------------|----------------------------|----------------------|
| 36045A | 14-3/16 (360) | 12-9/16 (319) | 9-5/16 (237) | 12-11/16 (322) | 4 (102) | 108 (49) |
| 42045B | 17-1/2 (445) | 15-7/8 (403) | 11-9/16 (294) | 16 (406) | 4 (102) | 121 (55) |
| 36070A | 14-3/16 (360) | 12-9/16 (319) | 9-5/16 (237) | 12-11/16 (322) | 4 (102) | 114 (52) |
| 36070B | 17-1/2 (445) | 15-7/8 (403) | 11-9/16 (294) | 16 (406) | 4 (102) | 124 (56) |
| 48070B | 17-1/2 (445) | 15-7/8 (403) | 11-9/16 (294) | 16 (406) | 4 (102) | 127 (58) |
| 48070C | 21 (533) | 19-3/8 (492) | 13-5/16 (338) | 19-1/2 (495) | 4 (102) | 139.5 (63) |
| 42090B | 17-1/2 (445) | 15-7/8 (403) | 11-9/16 (294) | 16 (406) | 4 (102) | 133 (60) |
| 48090C | 21 (533) | 19-3/8 (492) | 13-5/16 (338) | 19-1/2 (495) | 4 (102) | 140.5 (64) |
| 60090C | 21 (533) | 19-3/8 (492) | 13-5/16 (338) | 19-1/2 (495) | 4 (102) | 147 (67) |
| 60110C | 21 (533) | 19-3/8 (492) | 13-5/16 (338) | 19-1/2 (495) | 4 (102) | 150 (68) |
| 60110D | 24-1/2 (622) | 22-7/8 (581) | 15-1/16 (383) | 23 (584) | 4 (102) | 165 (75) |
| 60135D | 24-1/2 (622) | 22-7/8 (581) | 15-1/16 (383) | 23 (584) | 4 (102)* | 167 (76) |
| 60155D | 24-1/2 (622) | 22-7/8 (581) | 15-1/16 (383) | 23 (584) | 4 (102)* | 171 (77) |

*. 135 and 155 size furnaces requires a 5 or 6-in. (127 or 152 mm) vent. Use a vent adapter between furnace and vent stack. See Installation Instructions for complete installation requirements

SAFETY CONSIDERATIONS

WARNING

FIRE, INJURY, OR DEATH HAZARD

Failure to follow this warning could result in property damage, personal injury, or death.

This furnace was manufactured to operate with natural gas. When fuel supply is Liquid Propane (LP), this furnace must be converted with a factory approved LP conversion kit. See furnace rating plate for approved conversion kit.

WARNING

FIRE, EXPLOSION, ELECTRICAL SHOCK, AND CARBON MONOXIDE POISONING HAZARD

Failure to follow this warning could result in dangerous operation, serious injury, death, or property damage.

Improper installation, adjustment, alteration, service, maintenance, or use could cause carbon monoxide poisoning, explosion, fire, electrical shock, or other conditions which may cause personal injury or property damage. Consult a qualified service agency, local gas supplier, or your distributor or branch for information or assistance. The qualified service agency must use only factory-authorized accessories and replacement parts when installing and servicing this product.

WARNING

FIRE, EXPLOSION, ELECTRICAL SHOCK, AND CARBON MONOXIDE POISONING HAZARD

Failure to follow this warning could result in dangerous operation, personal injury, death, or property damage.

Furnaces shall NOT be twinned (i.e. tandem or staged operation) unless approved in factory technical specifications literature for the furnace. A factory authorized, field-supplied Twinning Kit MUST be used. Consult furnace pre-sale literature for specific models approved for twinning and the correct twinning kit. Twinned furnaces must be installed on both a common supply AND a common return duct system as shown in the Twinning Kit Installation Instructions. Only two furnaces can be twinned on a common supply and return duct system using a factory authorized twinning kit.

CAUTION

FURNACE RELIABILITY HAZARD

Improper installation or misapplication of furnace may require excessive servicing or cause premature component failure.

Application of this furnace should be indoors with special attention given to vent sizing and material, gas input rate, air temperature rise, unit leveling, and unit sizing.

WARNING

FIRE, INJURY, OR DEATH HAZARD

Failure to follow this warning could result in property damage, personal injury, or death.

Do not bypass any of the safety controls in the furnace, including but not limited to the main limit switch, rollout or burner thermal switch, and pressure switch/pressure transducer.

WARNING

PERSONAL INJURY AND PROPERTY DAMAGE HAZARD

Failure to follow this warning could result in property damage, personal injury, or death.

For continued performance, reliability, and safety, the only approved accessories and replacement parts are those specified by the equipment manufacturer. The use of non-manufacturer approved parts and accessories could invalidate the equipment limited warranty and result in fire risk, equipment malfunction, and failure. Please review manufacturer's instructions and replacement part catalogs available from your equipment supplier

Improper installation, adjustment, alteration, service, maintenance, or use can cause explosion, fire, electrical shock, or other conditions which may cause death, personal injury, or property damage. Consult a qualified installer, service agency, or your distributor or branch for information or assistance. The qualified installer or agency must use factory-authorized kits or accessories when modifying this product. Refer to the individual instructions packaged with the kits or accessories when installing.

Follow all safety codes. Wear safety glasses, protective clothing, and work gloves. Have a fire extinguisher available. Read these instructions thoroughly and follow all warnings or cautions include in literature and attached to the unit. Consult local building codes, the current editions of the current edition of National Fuel Gas Code (NFGC) NFPA 54/ANSI Z223.1 and the current edition of National Electrical Code (NEC) NFPA 70.

Recognize safety information. This is the safety-alert symbol . When you see this symbol on the unit and in instructions or manuals, be alert to the potential for personal injury.

Understand the signal words **DANGER**, **WARNING**, and **CAUTION**. These words are used with the safety-alert symbol. **DANGER** identifies the most serious hazards which will result in severe personal injury or death. **WARNING** signifies hazards which could result in personal injury or death. **CAUTION** is used to identify unsafe practices which may result in minor personal injury or product and property damage. **NOTE** is used to highlight suggestions which will result in enhanced installation, reliability, or operation.

CAUTION

CUT HAZARD

Failure to follow this caution may result in personal injury.

Sheet metal parts may have sharp edges or burrs. Use care and wear appropriate protective clothing, safety glasses and gloves when handling parts and servicing furnaces.

The following additional safety considerations should be followed for gas furnaces:

1. Use only with type of gas approved for this furnace. Refer to the furnace rating plate.
2. Install this furnace only in a location and position as specified in the "Location" section of these instructions.
3. Provide adequate combustion and ventilation air to the furnace space as specified in "Air for Combustion and Ventilation" section.
4. Combustion products must be discharged outdoors. Connect this furnace to an approved vent system only, as specified in the "Venting" section of these instructions.

5. Never test for gas leaks with an open flame. Use a commercially available soap solution made specifically for the detection of leaks to check all connections, as specified in the "Gas Piping" section.
6. Always install furnace to operate within the furnace's intended temperature-rise range with a duct system which has an external static pressure within the allowable range, as specified in the "Start-Up, Adjustments, and Safety Check" section. See furnace rating plate.
7. When a furnace is installed so that supply ducts carry air circulated by the furnace to areas outside the space containing the furnace, the return air shall also be handled by duct(s) sealed to the furnace casing and terminating outside the space containing the furnace. See "Air Ducts" section.
8. A gas-fired furnace for installation in a residential garage must be installed as specified in the warning box in the "Location" section.
9. The furnace may be used for construction heat provided that the furnace installation and operation complies with the first CAUTION in the LOCATION section of these instructions.
10. These Multipoise Gas-Fired Furnaces are CSA (formerly A.G.A. and C.G.A.) design-certified for use with natural and propane gases (see furnace rating plate) and for installation in alcoves, attics, basements, closets, utility rooms, crawlspaces, and garages. The furnace is factory-shipped for use with natural gas. A CSA listed accessory gas conversion kit is required to convert furnace for use with propane gas.
11. See Fig. 2 for required clearances to combustible construction.
12. Maintain a 1-in. (25 mm) clearance from combustible materials to supply air ductwork for a distance of 36 inches (914 mm) horizontally from the furnace. See current edition of NFPA 90B or local code for further requirements.
13. These furnaces SHALL NOT be installed directly on carpeting, tile, or any other combustible material other than wood flooring. In downflow installations, factory accessory floor base MUST be used when installed on combustible materials and wood flooring. Special base is not required when this furnace is installed on manufacturer's cased evaporator coils or when manufacturer's evaporator coil casing is used. See Fig. 2 for clearance to combustible construction information.

INTRODUCTION

| | | | |
|---|--|--|--|
| ⚠ WARNING | | ELECTRIC SHOCK AND MOVING PARTS HAZARD High voltage and rotating fan blades may be present in blower compartment when door switch is pressed. Keep hands clear. | |
| <p>⚠ WARNING FIRE, EXPLOSION, ASPHYXIATION HAZARD</p> <p>Improper adjustment, alteration, service, maintenance, or installation can cause serious injury or death.</p> <p>Read and follow instructions and precautions in User's Information Manual provided with this furnace. Installation and service must be performed by a qualified service agency or the gas supplier.</p> | | <p>INSTALLATION</p> <p>MINIMUM INCHES CLEARANCE TO COMBUSTIBLE CONSTRUCTION</p> <p>This forced air furnace is equipped for use with natural gas at altitudes 0 - 10,000 ft (0 - 3,050m). An accessory kit, supplied by the manufacturer, shall be used to convert to propane gas use or may be required for some natural gas applications. This furnace is for indoor installation in a building constructed on site. This furnace may be installed on combustible flooring in alcove or closet at minimum clearance as indicated by the diagram from combustible material. This furnace may be used with a Type B-1 Vent and may be vented in common with other gas fired appliances.</p> <p>This furnace is approved for UPFLOW, DOWNFLOW, and HORIZONTAL installations. Clearance arrows do not change with furnace orientation.</p> <p>Vent Clearance to combustibles: For Single Wall vents 6 inches (150 mm). For Type B-1 vent type 1 inch (25 mm).</p> | |
| <p>⚠ CAUTION</p> <p>Check entire gas assembly for leaks after lighting this appliance.</p> | | <p>INSTALLATION</p> <p>1. This furnace must be installed in accordance with the manufacturer's instructions and local codes. In the absence of local codes, follow the National Fuel Gas Code ANSI Z223.1 / NFPA54 or CSA B-149.1 Gas Installation Code.</p> <p>2. This furnace must be installed so there are provisions for combustion and ventilation air. See manufacturer's installation information provided with this appliance.</p> | |
| <p>OPERATION</p> <p>This furnace is equipped with manual reset limit switch(es) in burner compartment to protect against overheat conditions that can result from inadequate combustion air supply or blocked vent conditions.</p> <ol style="list-style-type: none"> 1. Do not bypass limit switches. 2. If a limit opens, call a qualified serviceman to correct the condition and reset limit switch. | | <p>MINIMUM INCHES CLEARANCE TO COMBUSTIBLE CONSTRUCTION</p> <p>DOWNFLOW POSITIONS:</p> <p>† Installation on non-combustible floors only. For installation on combustible flooring only when installed on a manufacturer approved special base kit or manufacturer recommended coil assembly.</p> <p>⊘ 18 inches front clearance required for alcove.</p> <p>* Indicates supply or return sides when furnace is in the horizontal position. Line contact only permissible between lines formed by intersections of the Top and two Sides of the furnace jacket, and building joists, studs or framing.</p> | |

Fig. 2 – Clearances to Combustibles

A220231

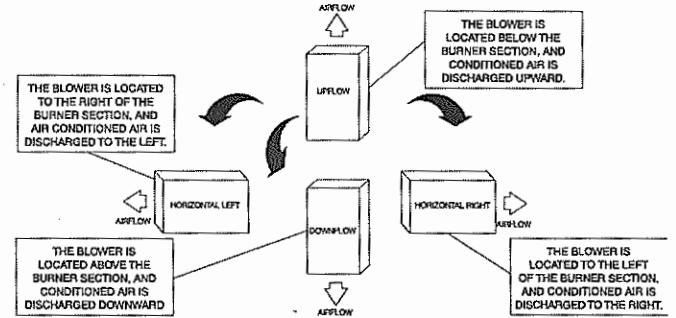

Fig. 3 – Multipoise Orientations

A02097

This 4-way multipoise Category I fan-assisted furnace is CSA design-certified. A Category I fan-assisted furnace is an appliance equipped with an integral mechanical means to either draw or force products of combustion through the combustion chamber and/or heat exchanger. The furnace is factory-shipped for use with natural gas.

This furnace is not approved for installation in mobile homes, recreational vehicles, or outdoors. This furnace is designed for minimum continuous return-air temperature of 60°F (16°C) db or intermittent operation down to 55°F (13°C) db such as when used with a night setback thermostat. Return-air temperature must not exceed 80°F (27°C) db. Failure to follow these return-air temperature limits may affect reliability of heat exchangers, motors, and controls (see Fig. 4).

For accessory installation details, refer to the applicable instruction literature.

NOTE: Remove all shipping brackets and materials before operating the furnace.

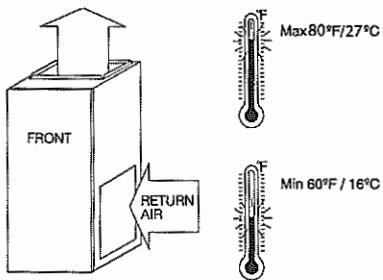

Fig. 4 – Return Air Temperature

A221115

! WARNING

FIRE HAZARD

Failure to follow this warning could result in personal injury, death and/or property damage.

Do not install the furnace on its back or hang furnace with control compartment facing downward. Safety control operation will be adversely affected. Never connect return-air ducts to the back of the furnace (see Fig. 5).

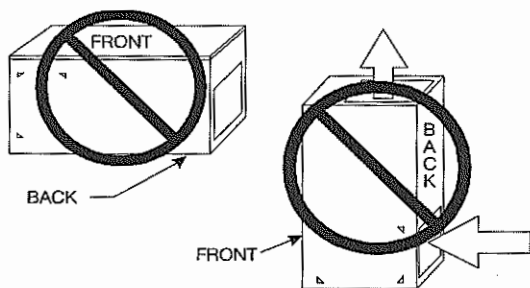

Fig. 5 – Prohibit Installation on Back

A02054

! WARNING

FIRE HAZARD

Failure to follow this warning could result in personal injury, death, and/or property damage.

When the furnace is installed in a residential garage, the burners and ignition sources must be located at least 18 inches above the floor. The furnace must be located or protected to avoid damage by vehicles. When the furnace is installed in a public garage, airplane hangar, or other building having a hazardous atmosphere, the furnace must be installed in accordance with the NFGC (see Fig. 6).

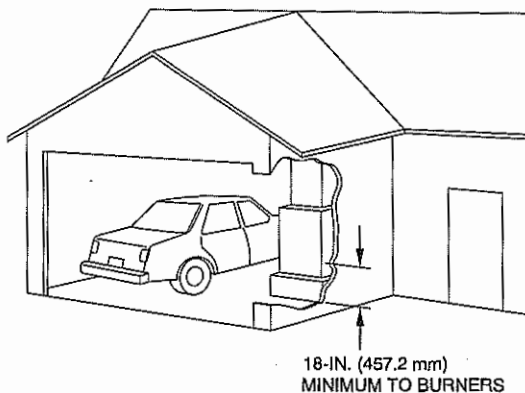

Fig. 6 – Installation in a Garage

A93044

CODES AND STANDARDS

Follow all national and local codes and standards in addition to these instructions. The installation must comply with regulations of the serving gas supplier, local building, heating, plumbing, and other codes. In absence of local codes, the installation must comply with the national codes listed below and all authorities having jurisdiction.

In the United States, follow all codes and standards for the following:

Safety

- USA: Current edition of National Fuel Gas Code (NFGC) NFPA 54/ANSI Z223.1 and the Installation Standards, Warm Air Heating and Air Conditioning Systems ANSI/NFPA 90B.

General Installation

- Current edition of the NFGC and the NFPA 90B. For copies, contact the National Fire Protection Association Inc., Batterymarch Park, Quincy, MA 02269; (www.NFPA.org) or for only the NFGC, contact the American Gas Association, 400 N. Capitol Street, N.W., Washington, DC 20001 (www.AGA.org).

Combustion and Ventilation Air

- Current edition of NFGC NFPA54/ANSI Z223.1 Section 9.3, Air for Combustion and Ventilation.

Duct Systems

- Air Conditioning Contractors Association (ACCA) Manual D, Sheet Metal and Air Conditioning Contractors National Association (SMACNA), or American Society of Heating, Refrigeration, and Air Conditioning Engineers (ASHRAE) 2005 Fundamentals Handbook Chapter 35 or 2004 HVAC Systems and Equipment Handbook Chapters 9 and 16.

Acoustical Lining and Fibrous Glass Duct

- Current edition of SMACNA and NFPA 90B as tested by UL Standard 181 for Class I Rigid Air Ducts.

Gas Piping and Gas Pipe Pressure Testing

- Current edition of NFGC NFPA 54/ANSI Z223.1; chapters 5, 6, 7, and 8 and National Plumbing Codes.

Electrical Connections

- Current edition of National Electrical Code (NEC) NFPA 70.

Venting

- Current edition of NFGC NFPA 54 / ANSI Z223.1; Chapters 12 and 13.

ELECTROSTATIC DISCHARGE (ESD) PRECAUTIONS PROCEDURE

1. Disconnect all power to the furnace. Multiple disconnects maybe required. **DO NOT TOUCH THE CONTROL OR ANY WIRE CONNECTED TO THE CONTROL PRIOR TO DISCHARGING YOUR BODY'S ELECTROSTATIC CHARGE TO GROUND.**

! CAUTION

FURNACE RELIABILITY HAZARD

Improper installation or service of furnace may cause premature furnace component failure.

Electrostatic discharge can affect electronic components. Follow the Electrostatic Discharge Precautions Procedure listed below during furnace installation and servicing to protect the furnace electronic control. Precautions will prevent electrostatic discharges from personnel and hand tools which are held during the procedure. These precautions will help to avoid exposing the control to electrostatic discharge by putting the furnace, the control, and the person at the same electrostatic potential.

2. Firmly touch the clean, unpainted, metal surface of the furnace chassis which is close to the control. Firmly touch the clean, unpainted, metal surface of the furnace chassis which is close to the control. Tools held in a person's hand during grounding will be satisfactorily discharged.
3. After touching the chassis, you may proceed to service the control or connecting wires as long as you do nothing to recharge your body with static electricity (for example; DO NOT move or shuffle your feet, do not touch ungrounded objects, etc.).
4. If you touch ungrounded objects (and recharge your body with static electricity), firmly touch a clean, unpainted metal surface of the furnace again before touching control or wires.
5. Use this procedure for installed and uninstalled (ungrounded) furnaces.
6. Before removing a new control from its container, discharge your body's electrostatic charge to ground to protect the control from damage. If the control is to be installed in a furnace, follow items 1 through 4 before bringing the control or yourself in contact with the furnace. Put all used and new controls into containers before touching ungrounded objects.
7. An ESD service kit (available from commercial sources) may also be used to prevent ESD damage.

LOCATION

GENERAL

This multipoise furnace is shipped in packaged configuration. Some assembly and modifications are required when used in any of the four applications (see Fig. 3).

This furnace must:

- be installed so the electrical components are protected from water.
- not be installed directly on any combustible material other than wood flooring for upflow applications. Downflow installations require use of a factory-approved floor base or coil assembly when installed on combustible materials or wood flooring (refer to SAFETY CONSIDERATIONS).
- be located as close to the chimney or vent and attached to an air distribution system. Refer to Air Ducts section.
- be provided ample space for servicing and cleaning. Always comply with minimum fire protection clearances shown on the furnace clearance to combustible label.

The following types of furnace installations may require OUTDOOR AIR for combustion due to chemical exposures:

- Commercial buildings
- Buildings with indoor pools
- Laundry rooms
- Hobby or craft rooms, and
- Chemical storage areas

If air is exposed to the following substances, it should not be used for combustion air, and outdoor air may be required for combustion:

- Permanent wave solutions
- Chlorinated waxes and cleaners
- Chlorine based swimming pool chemicals
- Water softening chemicals
- De-icing salts or chemicals
- Carbon tetrachloride
- Halogen type refrigerants
- Cleaning solvents (such as perchloroethylene)
- Printing inks, paint removers, varnishes, etc.
- Hydrochloric acid
- Cements and glues
- Antistatic fabric softeners for clothes dryers

- Masonry acid washing materials

All fuel-burning equipment must be supplied with air for fuel combustion. Sufficient air must be provided to avoid negative pressure in the equipment room or space. A positive seal must be made between the furnace cabinet and the return-air duct to prevent pulling air from the burner area and from draft safeguard opening.

LOCATION RELATIVE TO COOLING EQUIPMENT

The cooling coil must be installed parallel with, or on the downstream side of the unit to avoid condensation in the heat exchangers. When installed parallel with the furnace, dampers or other flow control must prevent chilled air from entering the furnace. If the dampers are manually operated, they must be equipped with means to prevent operation of either unit unless the damper is in the full-heat or full-cool position.



PERSONAL INJURY AND/OR PROPERTY DAMAGE HAZARD

Improper use or installation of this furnace may cause premature furnace component failure.

This gas furnace may be used for heating buildings under construction provided that:

- The furnace is permanently installed with all electrical wiring, piping, venting and ducting installed according to these installation instructions. A return air duct is provided, sealed to the furnace casing, and terminated outside the space containing the furnace. This prevents a negative pressure condition as created by the circulating air blower, causing a flame rollout and/or drawing combustion products into the structure.
- The furnace is controlled by a thermostat. It may not be "hot wired" to provide heat continuously to the structure without thermostatic control.
- Clean outside air is provided for combustion. This is to minimize the corrosive effects of adhesives, sealers and other construction materials. It also prevents the entrainment of drywall dust into combustion air, which can cause fouling and plugging of furnace components.
- The temperature of the return air to the furnace is maintained between 55°F (13°C) and 80°F (27°C), with no evening setback or shutdown. The use of the furnace while the structure is under construction is deemed to be intermittent operation per our installation instructions.
- The air temperature rise is within the rated rise range on the furnace rating plate, and the gas input rate has been set to the nameplate value.
- The filters used to clean the circulating air during the construction process must be either changed or thoroughly cleaned prior to occupancy.
- The furnace, ductwork and filters are cleaned as necessary to remove drywall dust and construction debris from all HVAC system components after construction is completed.
- Verify proper furnace operating conditions including ignition, gas input rate, air temperature rise, and venting according to these installation instructions.

! WARNING

CARBON MONOXIDE POISONING HAZARD

Failure to follow this warning could result in personal injury or death, and unit component damage.

Corrosive or contaminated air may cause failure of parts containing flue gas, which could leak into the living space. Air for combustion must not be contaminated by halogen compounds, which include fluoride, chloride, bromide, and iodide. These elements can corrode heat exchangers and shorten furnace life. Air contaminants are found in aerosol sprays, detergents, bleaches, cleaning solvents, salts, air fresheners, and other household products. Do not install furnace in a corrosive or contaminated atmosphere. Make sure all combustion and circulating air requirements are met, in addition to all local codes and ordinances.

! CAUTION

FURNACE CORROSION HAZARD

Failure to follow this caution may result in furnace damage.

Air for combustion must not be contaminated by halogen compounds, which include fluoride, chloride, bromide, and iodide. These elements can corrode heat exchangers and shorten furnace life. Air contaminants are found in aerosol sprays, detergents, bleaches, cleaning solvents, salts, air fresheners, and other household products.

AIR FOR COMBUSTION AND VENTILATION

Provisions for adequate combustion, ventilation, and dilution air must be provided in accordance with:

- U.S. installations: Section 9.3 of the current edition of NFPA 54/ANSI Z223.1, Air for Combustion and Ventilation, and applicable provisions of the local building codes.

! WARNING

CARBON MONOXIDE POISONING HAZARD

Failure to follow this warning could result in personal injury or death. The operation of exhaust fans, kitchen ventilation fans, clothes dryers, attic exhaust fans or fireplaces could create a **NEGATIVE PRESSURE CONDITION** at the furnace. Make-up air **MUST** be provided for the ventilation devices, in addition to that required by the furnace. Refer to Carbon Monoxide Poisoning Hazard warning in venting section of these instructions to determine if an adequate amount of make-up air is available.

The requirements for combustion and ventilation air depend upon whether or not the furnace is located in a space having a volume of at least 50 cubic feet per 1,000 BTU/h input rating for all gas appliances installed in the space.

- Spaces having less than 50 cubic feet per 1,000 BTU/h require the **OUTDOOR COMBUSTION AIR METHOD**.
- Spaces having at least 50 cubic feet per 1,000 BTU/h may use the **INDOOR COMBUSTION AIR, STANDARD** or **KNOWN AIR INFILTRATION METHOD**.

Outdoor Combustion Air Method

1. Provide the space with sufficient air for proper combustion, ventilation, and dilution of flue gases using permanent horizontal or vertical duct(s) or opening(s) directly communicating with the outdoors or spaces that freely communicate with the outdoors.

2. Fig. 7 illustrates how to provide **TWO OUTDOOR OPENINGS**, one inlet and one outlet combustion and ventilation air opening, to the outdoors.
 - a. One opening **MUST** commence within 12-in. (300 mm) of the ceiling and the second opening **MUST** commence within 12-in. (300 mm) of the floor.
 - b. Size openings and ducts per Fig. 7 and Table 2.
 - c. **TWO HORIZONTAL DUCTS** require 1 square inch of free area per 2,000 BTU/h (1,100 mm²/kW) of combined input for all gas appliances in the space per Fig. 7 and Table 2.
 - d. **TWO OPENINGS OR VERTICAL DUCTS** require 1 square inch of free area per 4,000 BTU/h (550 mm²/kW) for combined input of all gas appliances in the space per Fig. 7 and Table 2.
3. **ONE OUTDOOR OPENING** requires:
 - a. 1 square inch of free area per 3,000 BTU/h (734 mm²/kW) for combined input of all gas appliances in the space per Table 2 and
 - b. Not less than the sum of the areas of all vent connectors in the space.

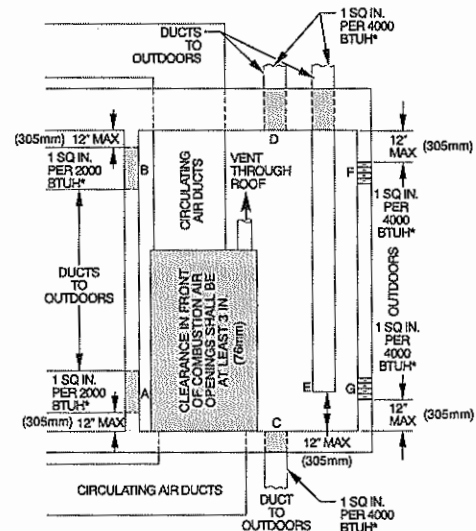

* Minimum dimensions of 3 in. (76 mm).

A03174

NOTE: Use any of the following combinations of openings: A&B, C&D, D&E, F&G
Fig. 7 – Air for Combustion, Ventilation, and Dilution for Outdoors

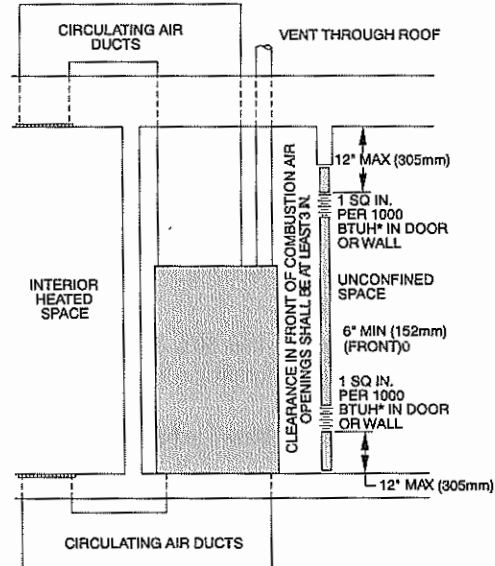

* Minimum opening size is 100 in.2 with minimum dimensions of 3 in. (76 mm).

A03175

* Minimum of 3 in. (76 mm), when type -B1 vent is used.

Fig. 8 – Air for Combustion, Ventilation, and Dilution from Indoors

The opening shall commence within 12" (300 mm) of the ceiling. Appliances in the space shall have clearances of at least 1" (25 mm) from the sides and back and 6" (150 mm) from the front. The opening shall directly communicate with the outdoors or shall communicate through a vertical or horizontal duct to the outdoors or spaces (crawl or attic) that freely communicate with the outdoors.

Indoor Combustion Air - NFPA & AGA

Standard and Known-Air-Infiltration Rate Methods

Indoor air is permitted for combustion, ventilation, and dilution, if the Standard or Known-Air-Infiltration Method is used.

WARNING

CARBON MONOXIDE POISONING HAZARD

Failure to follow this warning could result in death and/or personal injury.

Many homes require air to be supplied from outdoors for furnace combustion, ventilation, and dilution of flue gases. The furnace combustion air supply must be provided in accordance with this instruction manual.

Table 2 – Minimum Free Area Required for Each Combustion Air Opening or Duct to Outdoors

| FURNACE INPUT (BTUH) | TWO HORIZONTAL DUCTS (1 SQ. IN./2,000 BTUH) (1,100 SQ. MM/KW) | | SINGLE DUCT OR OPENING (1 SQ. IN./3,000 BTUH) (734 SQ. MM/KW) | | TWO OPENINGS OR VERTICAL DUCTS (1 SQ. IN./4,000 BTUH) (550 SQ. MM/KW) | |
|----------------------|---|------------------------------|---|--------------------------------|---|------------------------------|
| | Free Area of Opening and Duct (sq. in. / sq. mm) | Round Duct Diameter (in./mm) | Free Area of Opening and Duct (sq. in. / sq. mm) | Round Duct Diameter (in. / mm) | Free Area of Opening and Duct (sq. in. / sq. mm) | Round Duct Diameter (In./mm) |
| 44,000 | 22 (14193) | 6 (152) | 14.7 (9484) | 5 (127) | 11 (7097) | 4 (102) |
| 66,000 | 33 (21290) | 7 (178) | 22 (14193) | 6 (152) | 16.5 (10645) | 5 (127) |
| 88,000 | 44 (28387) | 8 (203) | 29.3 (18903) | 7 (178) | 22 (14193) | 6 (152) |
| 110,000 | 55 (35484) | 9 (229) | 36.7 (23677) | 7 (178) | 27.5 (17742) | 6 (152) |
| 132,000 | 66 (42581) | 10 (254) | 44 (28387) | 8 (203) | 33 (21290) | 7 (178) |
| 154,000 | 77 (49677) | 10 (254) | 51.3 (33096) | 9 (229) | 38.5 (24839) | 8 (203) |

EXAMPLES: Determining Free Area

| FURNACE | + | WATER HEATER | = | TOTAL INPUT | = | |
|---------|---|--------------|---|----------------------------|---|--|
| 110,000 | | 30,000 | | (140,000 divided by 4,000) | | 35.0 Sq. In. for each two Vertical Ducts or Openings |
| 66,000 | | 40,000 | | (106,000 divided by 3,000) | | 35.3 Sq. In. for a Single Duct or Opening |
| 88,000 | | 30,000 | | (118,000 divided by 2,000) | | 59.0 Sq. In. for each of two Horizontal Ducts |

Table 3 – Minimum Space Volumes for 100% Combustion, Ventilation, and Dilution from Indoors

| ACH* | OTHER THAN FAN-ASSISTED TOTAL (1,000'S BTUH GAS INPUT RATE) | | | FAN-ASSISTED TOTAL (1,000'S BTUH GAS INPUT RATE) | | | | |
|------|--|-------|--------|---|-------|--------|--------|--------|
| | 30 | 40 | 50 | 44 | 66 | 88 | 110 | 132 |
| | Space Volume (ft. ³) | | | | | | | |
| 0.60 | 1,050 | 1,400 | 1,750 | 1,100 | 1,650 | 2,200 | 2,750 | 3,300 |
| 0.50 | 1,260 | 1,680 | 2,100 | 1,320 | 1,980 | 2,640 | 3,300 | 3,960 |
| 0.40 | 1,575 | 2,100 | 2,625 | 1,650 | 2,475 | 3,300 | 4,125 | 4,950 |
| 0.30 | 2,100 | 2,800 | 3,500 | 2,200 | 3,300 | 4,400 | 5,500 | 6,600 |
| 0.20 | 3,150 | 4,200 | 5,250 | 3,300 | 4,950 | 6,600 | 8,250 | 9,900 |
| 0.10 | 6,300 | 8,400 | 10,500 | 6,600 | 9,900 | 13,200 | 16,500 | 19,800 |
| 0.00 | NP | NP | NP | NP | NP | NP | NP | NP |

*. Air Changes/Hour

The Standard Method

Use the **Standard Method** if:

1. The space has no less volume than 50 cubic feet per 1,000 BTU_h of the maximum input ratings for all gas appliances installed in the space and
2. The air infiltration rate is not known to be less than 0.40 air changes per hour (ACH).

Use the **Known Air Infiltration Rate Method** if the infiltration rate is known to be:

1. Less than 0.40 ACH and
2. Equal to or greater than 0.10 ACH

Infiltration rates greater than 0.60 ACH shall not be used. The minimum required volume of the space varies with the number of ACH and shall be determined per Table 3 or Equations 1 and 2. Determine the minimum

required volume for each appliance in the space and add the volumes together to get the total minimum required volume for the space.

Table 3 - Minimum Space Volumes were determined by using the following equations from the current edition of National Fuel Gas Code ANSI Z223.1/NFPA 54:

1. For other than fan-assisted appliances, such as a draft hood-equipped water heater:

$$\text{Volume}_{\text{Other}} = \frac{21 \text{ ft}^3}{\text{ACH}} \left(\frac{I_{\text{Other}}}{1000 \text{ Btu/hr}} \right)$$

A04002

2. For fan-assisted appliances such as this furnace:

$$\text{Volume}_{\text{Fan}} = \frac{15 \text{ ft}^3}{\text{ACH}} \left(\frac{I_{\text{Fan}}}{1000 \text{ Btu/hr}} \right)$$

A04003

If the following is applied to either equation:

- ¹other = combined input of all other than fan-assisted appliances in BTU_h/hr
- ¹fan = combined input of all fan-assisted appliances in BTU_h/hr
- ACH = air changes per hour (ACH shall not exceed 0.60.)

The following requirements apply to the **Standard Method** and to the **Known Air Infiltration Rate Method**.

1. Adjoining rooms can be considered part of a space if:
 - a. There are no closeable doors between rooms.
 - b. Combining spaces on same floor level. Each opening shall have free area of at least 1 in.²/1,000 BTU_h (2,000 mm²/kW) of the total input rating of all gas appliances in the space, but not less than 100 in.² (0.06 m²). One opening shall commence within 12" (300 mm) of the ceiling and the second opening shall commence within 12" (300 mm) of the floor. The minimum dimension of air openings shall be at least 3 in. (80 mm) (see Fig. 8).
 - c. Combining space on different floor levels. The volumes of spaces on different floor levels shall be considered as communicating spaces if connected by one or more permanent openings in doors or floors having free area of at least 2 in.²/1,000 BTU_h (4,400 mm²/kW) of total input rating of all gas appliances.
2. An attic or crawlspace may be considered a space that freely communicates with the outdoors provided there are adequate permanent ventilation openings directly to outdoors having free area of at least 1-in.²/4,000 BTU_h of total input rating for all gas appliances in the space.
3. In spaces that use the Indoor Combustion Air Method, infiltration should be adequate to provide air for combustion, permanent ventilation and dilution of flue gases. However, in buildings with unusually tight construction, additional air **MUST** be provided using the methods described in the Outdoor Combustion Air Method section.
4. Unusually tight construction is defined as construction with:
 - a. Walls and ceilings exposed to the outdoors have a continuous, sealed vapor barrier. Openings are gasketed or sealed and
 - b. Doors and openable windows are weatherstripped and
 - c. Other openings are caulked or sealed. These include joints around window and door frames, between sole plates and floors, between wall-ceiling joints, between wall panels, at penetrations for plumbing, electrical and gas lines, etc.

Combination of Indoor and Outdoor Air

1. Indoor openings shall comply with the Indoor Combustion Air Method below and,
2. Outdoor openings shall be located as required in the Outdoor Combustion Air Method mentioned previously and,
3. Outdoor openings shall be sized as follows:
 - a. Calculate the Ratio of all Indoor Space volume divided by required volume for Indoor Combustion Air Method below.
 - b. Outdoor opening size reduction Factor is 1 minus the Ratio in a. above.
 - c. Minimum size of Outdoor openings shall be the size required in Outdoor Combustion Air Method above multiplied by reduction Factor in b. above. The minimum dimension of air openings shall be not less than 3 in. (80 mm).

INSTALLATION

Upflow Installation

Bottom Return Air Inlet

These furnaces are shipped with bottom closure panel installed in bottom return-air opening. Remove and discard this panel when bottom return air is used. To remove bottom closure panel, perform the following:

1. Tilt or raise furnace and remove two screws holding bottom filler panel (see Fig. 9).
2. Rotate bottom filler panel downward to release holding tabs.
3. Remove bottom closure panel.
4. Reinstall bottom filler panel and screws.

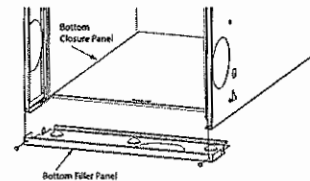

Fig. 9 – Removing Bottom Closure Panel

A10273

Side Return Air Inlet

These furnaces are shipped with bottom closure panel installed in bottom return-air opening. This panel **MUST** be in place when only side return air is used.

NOTE: Side return-air openings can be used in UPFLOW and most HORIZONTAL configurations. Do not use side return-air openings in DOWNFLOW configuration.

Leveling Legs (If Desired)

In upflow position with side return inlet(s), leveling legs may be used (see Fig. 10). Install field-supplied, 5/16 x 1-1/2 in. (8 x 38 mm) (max) corrosion-resistant machine bolts, washers and nuts.

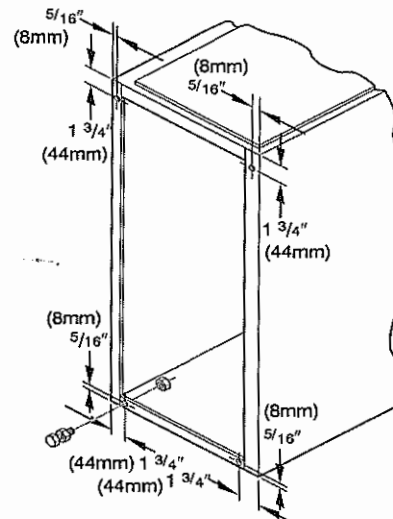

Fig. 10 – Leveling Legs

A89014

NOTE: Bottom closure must be used when leveling legs are used. It may be necessary to remove and reinstall bottom closure panel to install leveling legs. To remove bottom closure panel, see Item 1. in Bottom Return Air Inlet section.

To install leveling legs:

1. Position furnace on its back. Locate and drill a hole in each bottom corner of furnace (see Fig. 10).
2. For each leg, install nut on bolt and then install bolt and nut in hole. (Install flat washer if desired.)

3. Install another nut on other side of furnace base. (Install flat washer if desired.)
4. Adjust outside nut to provide desired height, and tighten inside nut to secure arrangement.
5. Reinstall bottom closure panel if removed.

Downflow Installation

! CAUTION

EQUIPMENT OR PROPERTY DAMAGE

Failure to follow this caution could result in equipment or property damage

When furnace is installed in a downflow application, make sure water lines and other sources of water cannot drip or fail in such a way that water can collect on the blower motor, wiring, and furnace control board.

NOTE: For downflow applications, this furnace is approved for use on combustible flooring when any one of the following 3 accessories are used:

- Manufacturer’s approved downflow combustible floor subbase
 - Manufacturer’s approved cased evaporator coil
 - Manufacturer’s approved evaporator coil casing
1. Determine application being installed from Table 4.
 2. Construct hole in floor (see Table 4 and Fig. 11).
 3. Construct plenum to dimensions specified (see Table 4 and Fig. 11).
 4. If downflow subbase is used, install as shown in Fig. 12. If manufacturer’s cased evaporator coil or coil casing is used, install as shown in see Fig. 13.

NOTE: It is required that the perforated supply-air duct flanges be completely folded over or removed from furnace when installing the furnace on a factory-supplied cased coil or coil box. To remove the supply-air duct flange, use wide duct pliers or hand seamers to bend flange back and forth until it breaks off. Be careful of sharp edges. Refer to Duct Flanges (Fig. 17) in the “Air Ducts” section.

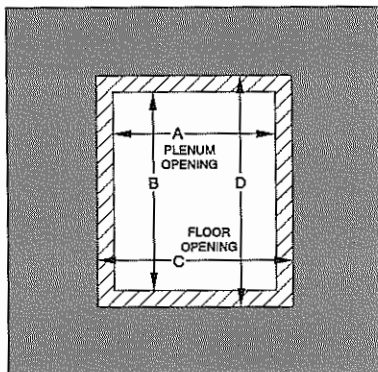

Fig. 11 – Floor and Plenum Opening Dimensions

A96283

Bottom Return Air Inlet

These furnaces are shipped with bottom closure panel installed in bottom return-air opening. Remove and discard this panel when bottom return air is used. To remove bottom closure panel, perform the following:

1. Tilt or raise furnace and remove two screws holding bottom filler panel (see Fig. 9).
2. Rotate bottom filler panel downward to release holding tabs.
3. Remove bottom closure panel.
4. Reinstall bottom filler panel and screws

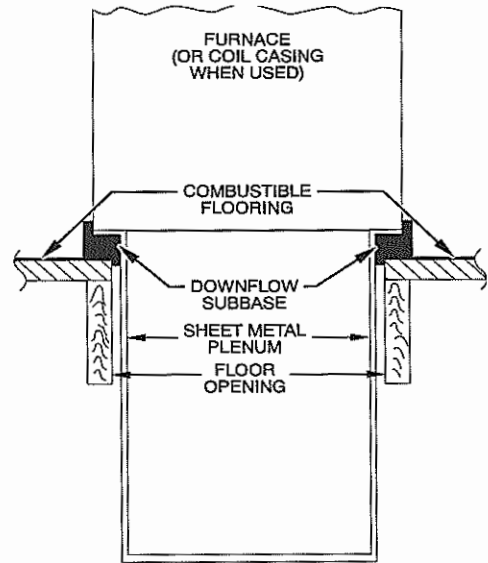

Fig. 12 – Furnace, Plenum, and Subbase Installed on a Combustible Floor

A96285

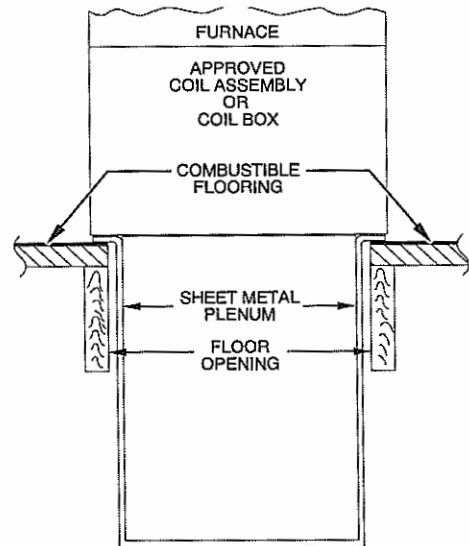

Fig. 13 – Furnace, Plenum, and Coil Assembly or Coil Box Installed on a Combustible Floor

A08556

Table 4 – Opening Dimensions - In. (mm)

| FURNACE CASING WIDTH | APPLICATION | PLENUM OPENING | | FLOOR OPENING | |
|----------------------|--|-------------------|-----------------|------------------|-----------------|
| | | A | B | C | D |
| 14-3/16 (360) | Upflow Applications on Combustible or Noncombustible Flooring (subbase not required) | 12-11/16 (322) | 21-5/8 (549) | 13-5/16 (338) | 22-1/4 (565) |
| | Downflow Applications on Noncombustible Flooring (subbase not required) | 12-9/16 (319) | 19 (483) | 13-3/16 (335) | 19-5/8 (498) |
| | Downflow Applications on Combustible Flooring (subbase required) | 11-13/16 (284) | 19 (483) | 13-7/16 (341) | 20-5/8 (600) |
| | Downflow Applications on Combustible Flooring with Cased Coil (subbase not required) | 12-5/16 (319) | 19 (483) | 13-5/16 (338) | 20 (508) |
| 17-1/2 (445) | Upflow Applications on Combustible or Noncombustible Flooring (subbase not required) | 16 (406) | 21-5/8 (549) | 16-5/8 (422) | 22-1/4 (565) |
| | Downflow Applications on Noncombustible Flooring (subbase not required) | 15-7/8 (403) | 19 (483) | 16-1/2 (419) | 19-5/8 (498) |
| | Downflow Applications on Combustible Flooring (subbase required) | 15-1/8 (384) | 19 (483) | 16-3/4 (425) | 20-5/8 (600) |
| | Downflow Applications on Combustible Flooring with Cased Coil (subbase not required) | 15-1/2 (394) | 19 (483) | 16-1/2 (419) | 20 (508) |
| 21 (533) | Upflow Applications on Combustible or Noncombustible Flooring (subbase not required) | 19-1/2 (495) | 21-5/8 (549) | 20-1/8 (511) | 22-1/4 (565) |
| | Downflow Applications on Noncombustible Flooring (subbase not required) | 19-3/8 (492) | 19 (483) | 20 (508) | 19-5/8 (498) |
| | Downflow Applications on Combustible Flooring (subbase required) | 18-5/8 (473) | 19 (483) | 20-1/4 (514) | 20-5/8 (600) |
| | Downflow Applications on Combustible Flooring with Cased Coil (subbase not required) | 19 (483) | 19 (483) | 20 (508) | 20 (508) |
| 24-1/2 (622) | Upflow Applications on Combustible or Noncombustible Flooring (subbase not required) | 23 (584) | 21-1/8 (537) | 23-5/8 (600) | 22-1/4 (565) |
| | Downflow Applications on Noncombustible Flooring (subbase not required) | 22-7/8 (581) | 19 (483) | 23-1/2 (597) | 19-5/8 (498) |
| | Downflow Applications on Combustible flooring (subbase required) | 22-1/8 (562) | 19 (483) | 23-3/4 (603) | 20-5/8 (600) |
| | Downflow Applications on Combustible Flooring with Cased Coil (subbase not required) | 22-1/2 (572) | 19 (483) | 23-1/2 (597) | 20 (508) |

⚠ WARNING

FIRE, EXPLOSION, AND CARBON MONOXIDE POISONING HAZARD

Failure to follow this warning could result in personal injury, death, and/or property damage.

Do not install the furnace on its back or hang furnace with control compartment facing downward. Safety control operation will be adversely affected. Never connect return-air ducts to the back of the furnace.

Horizontal Installation

The furnace can be installed horizontally in an attic or crawl space on either the left-hand (LH) or right-hand (RH) side. The furnace can be hung from floor joists, rafters or trusses or installed on a non-combustible platform, blocks, bricks or pad.

Suspended Furnace Support

The furnace may be supported under each end with threaded rod, angle iron or metal plumber's strap as shown (see Fig. 15 and Fig. 16). Secure angle iron to bottom of furnace as shown. Heavy-gauge sheet metal straps (plumber's straps) may be used to suspend the furnace from each bottom corner. To prevent screws from pulling out, use 2 #8 x 3/4-in. (19 mm) screws into the side and 2 #8 x 3/4-in. (19 mm) screws in the bottom of the furnace casing for each strap (see Fig. 15 and Fig. 16). If the screws are attached to ONLY the furnace sides and not the bottom, the straps must be vertical against the furnace sides and not pull away

from the furnace sides, so that the strap attachment screws are not in tension (are loaded in shear) for reliable support.

Platform Furnace Support

Construct working platform at location where all required furnace clearances are met (see Fig. 2 and Fig. 14). For furnaces with 1-in. (25 mm) clearance requirement on side, set furnace on noncombustible blocks, bricks or angle iron. For crawl space installations, if the furnace is not suspended from the floor joists, the ground underneath furnace must be level and the furnace set on blocks or bricks.

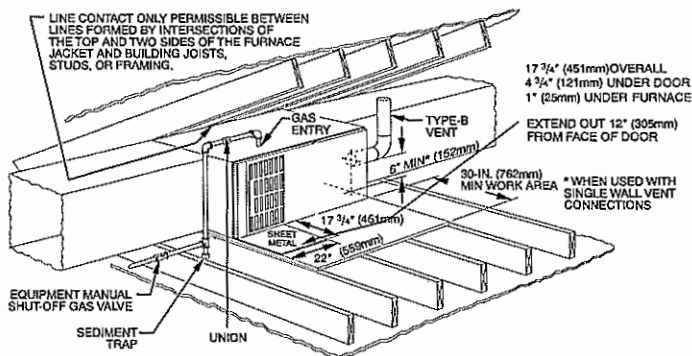

Fig. 14 – Typical Attic Installation

A10164

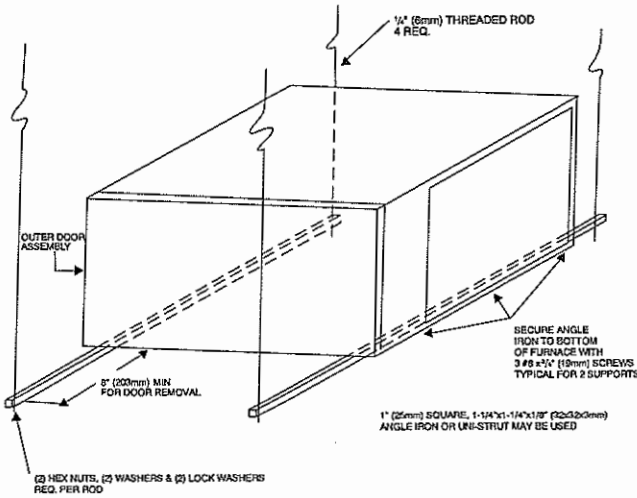

Fig. 15 – Horizontal Unit Suspension

A10130

Roll-Out Protection

Provide a minimum 17-3/4 in. x 22 in. (451 mm x 559 mm) piece of sheet metal for flame roll-out protection in front of burner area for furnaces closer than 12 inches (305 mm) above the combustible deck or suspended furnaces closer than 12 inches (305 mm) to joists. The sheet metal **MUST** extend underneath the furnace casing by 1 in. (25 mm) with the door removed.

The bottom closure panel on furnaces of widths 17-1/2 in. (445 mm) and larger may be used for flame roll-out protection when bottom of furnace is used for return air connection. See Fig. 14 for proper orientation of roll-out shield.

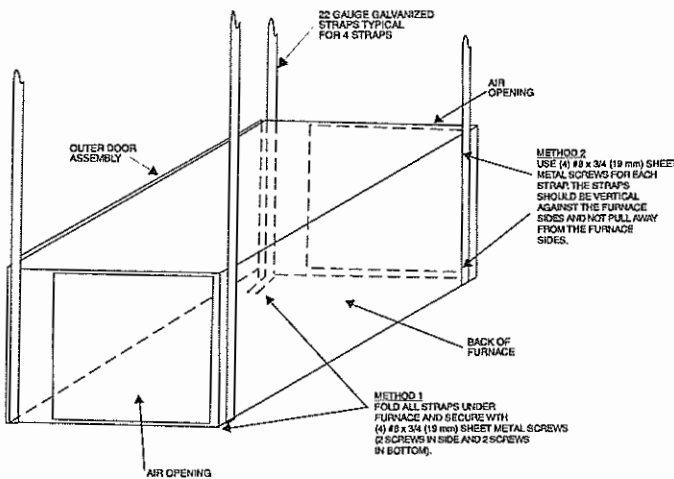

Fig. 16 – Horizontal Suspension with Straps

A10131

Bottom Return Air Inlet

These furnaces are shipped with bottom closure panel installed in bottom return-air opening. Remove and discard this panel when bottom return air is used. To remove bottom closure panel, perform the following:

1. Tilt or raise furnace and remove two screws holding bottom filler panel (see Fig. 9).
2. Rotate bottom filler panel downward to release holding tabs.
3. Remove bottom closure panel.
4. Reinstall bottom filler panel and screws. Side Return Air Inlet

Side Return Air Inlet

These furnaces are shipped with bottom closure panel installed in bottom return-air opening. This panel **MUST** be in place when side return air inlet(s) is used without a bottom return air inlet.

Not all horizontal furnaces are approved for side return air connections (see Fig. 20).

FILTER ARRANGEMENT

⚠ WARNING

CARBON MONOXIDE AND POISONING HAZARD

Failure to follow this warning could result in personal injury, or death. Never operate a furnace without a filter or with filter access door removed.

There are no provisions for an internal filter rack in these furnaces.

A field-supplied accessory external filter is required.

Refer to the instructions supplied with the external filter rack for assembly and installation options.

AIR DUCTS

General Requirements

The duct system should be designed and sized according to accepted national standards such as those published by: Air Conditioning Contractors Association (ACCA), Sheet Metal and Air Conditioning Contractors National Association (SMACNA) or American Society of Heating, Refrigerating and Air Conditioning Engineers (ASHRAE) or consult The Air Systems Design Guidelines reference tables available from your local distributor. The duct system should be sized to handle the required system design CFM at the design external static pressure. The furnace airflow rates are provided in Table 9-AIR DELIVERY-CFM (with filter).

When a furnace is installed so that the supply ducts carry air circulated by the furnace to areas outside the space containing the furnace, the return air shall also be handled by duct(s) sealed to the furnace casing and terminating outside the space containing the furnace.

Secure ductwork with proper fasteners for type of ductwork used. Seal supply- and return-duct connections to furnace with code approved tape or duct sealer.

NOTE: Flexible connections should be used between ductwork and furnace to prevent transmission of vibration. Ductwork passing through unconditioned space should be insulated and sealed to enhance system performance. When air conditioning is used, a vapor barrier is recommended.

Maintain a 1-in. (25 mm) clearance from combustible materials to supply air ductwork for a distance of 36 in. (914 mm) horizontally from the furnace. See NFPA 90B or local code for further requirements.

Ductwork Acoustical Treatment

NOTE: Metal duct systems that do not have a 90 degree elbow and 10 ft. (3 M) of main duct to the first branch take-off may require internal acoustical lining. As an alternative, fibrous ductwork may be used if constructed and installed in accordance with the latest edition of SMACNA construction standard on fibrous glass ducts. Both acoustical lining and fibrous ductwork shall comply with NFPA 90B as tested by UL Standard 181 for Class 1 Rigid air ducts.

Supply Air Connections

For a furnace not equipped with a cooling coil, the outlet duct shall be provided with a removable access panel. This opening shall be accessible when the furnace is installed and shall be of such a size that the heat exchanger can be viewed for possible openings using light assistance or a probe can be inserted for sampling the airstream. The cover attachment shall prevent leaks.

Upflow and Horizontal Furnaces

Connect supply-air duct to flanges on furnace supply-air outlet. Bend flange upward to 90° with wide duct pliers (see Fig. 17). The supply-air duct must be connected to ONLY the furnace supply-outlet-air duct flanges or air conditioning coil casing (when used). DO NOT cut main furnace casing side to attach supply air duct, humidifier, or other accessories. All accessories MUST be connected to duct external to furnace main casing.

NOTE: For horizontal applications, the top-most flange may be bent past 90 degrees to allow the evaporator coil to hang on the flange temporarily while the remaining attachment and sealing of the coil are performed.

Downflow Furnaces

Connect supply-air duct to supply-air outlet on furnace. Bend flange inward past 90° with wide duct pliers (see Fig. 17). The supply-air duct must be connected to ONLY the furnace supply outlet or air conditioning coil casing (when used). When installed on combustible material, supply-air duct must be connected to ONLY the factory-approved accessory subbase or a factory-approved air conditioning coil casing. DO NOT cut main furnace casing to attach supply side air duct, humidifier, or other accessories. All accessories MUST be connected to duct external to furnace casing.

Return Air Connections

CAUTION

FIRE HAZARD

Failure to follow this warning could cause personal injury, death and/or property damage.

Never connect return-air ducts to the back of the furnace. Follow instructions below.

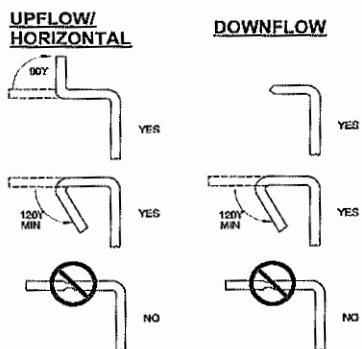

Fig. 17 – Duct Flanges

A190346

Downflow Furnaces

The return-air duct must be connected to return-air opening bottom inlet (see Fig. 1). DO NOT cut into casing sides (left or right). Side opening is permitted for only upflow and most horizontal furnaces (see Fig. 18). Bypass humidifier connections should be made at ductwork or coil casing sides exterior to furnace.

Upflow Furnaces

The return-air duct must be connected to bottom, sides (left or right), or a combination of bottom and side(s) of main furnace casing (see Fig. 19 and Fig. 20). Bypass humidifier may be attached into unused return air side of the furnace casing (see Fig. 19 and Fig. 20). Not all horizontal furnaces are approved for side return air connections (see Fig. 20).

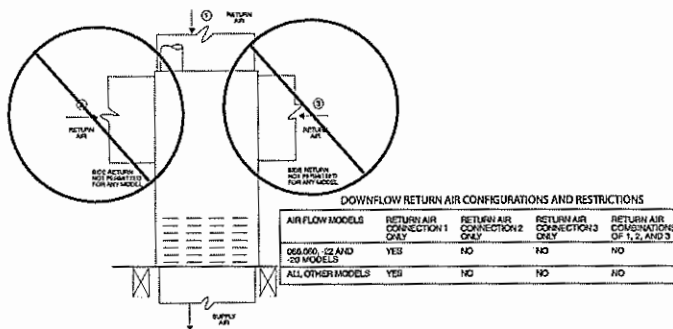

Fig. 18 – Downflow Return Air Configurations and Restrictions

A02163

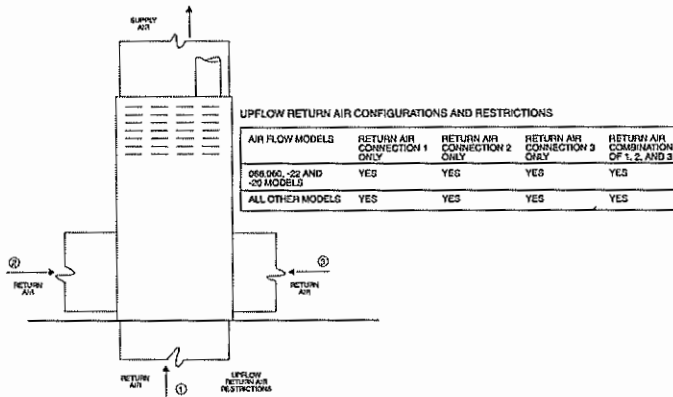

Fig. 19 – Upflow Return Air Configurations and Restrictions

A02075

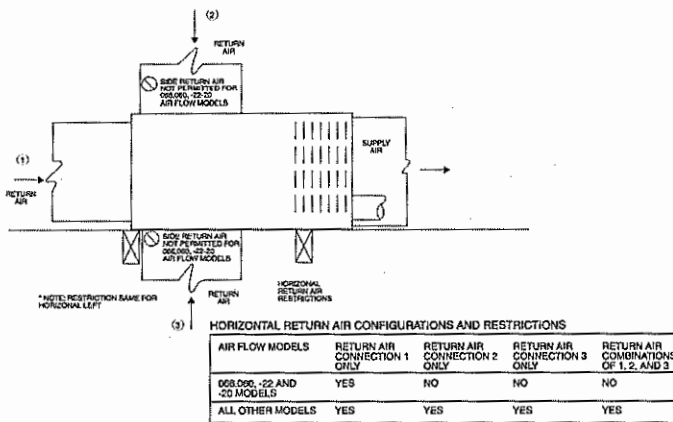

Fig. 20 – Horizontal Return Air Configurations and Restrictions

A02162

GAS PIPING

Gas piping must be installed in accordance with national and local codes. Refer to current edition of NFPGC.

Installations must be made in accordance with all authorities having jurisdiction. If possible, the gas supply line should be a separate line running directly from meter to furnace.

NOTE: In the state of Massachusetts:

1. Gas supply connections MUST be performed by a licensed plumber or gas fitter.
2. When flexible connectors are used, the maximum length shall not exceed 36 inches (915 mm).
3. When lever handle type manual equipment shutoff valves are used, they shall be T-handle valves.
4. The use of copper tubing for gas piping is NOT approved by the state of Massachusetts.

! WARNING

FIRE OR EXPLOSION HAZARD

Failure to follow this warning could result in personal injury, death, and/or property damage.
 Never purge a gas line into a combustion chamber. Never test for gas leaks with an open flame. Use a commercially available soap solution made specifically for the detection of leaks to check all connections.

! WARNING

FIRE OR EXPLOSION HAZARD

Failure to follow this warning could result in personal injuriousness, and/or property damage.
 Use proper length of pipe to avoid stress on gas control assembly and a gas leak.

! WARNING

FIRE OR EXPLOSION HAZARD

Failure to follow this warning could result in personal injury, death, and/or property damage.
 Gas valve inlet and/or inlet pipe must remain capped until gas supply line is permanently installed to protect the valve from moisture and debris. Also, install a sediment trap in the gas supply piping at the inlet to the gas valve.

Refer to Table 5 for recommended gas pipe sizing. Risers must be used to connect to furnace and to meter. Support all gas piping with appropriate straps, hangers, etc. Use a minimum of 1 hanger every 6 ft. (2 M). Joint compound (pipe dope) should be applied sparingly and only to male threads of joints. Pipe dope must be resistant to the action of propane gas.

Table 5 – Maximum Capacity of Pipe*

| NOMINAL IRON PIPE SIZE IN. (mm) | INTERNAL DIAMETER In. (mm) | LENGTH OF PIPE - FT. (M) | | | | |
|---------------------------------|----------------------------|--------------------------|------------|------------|-----------|-----------|
| | | 10 | 20 | 30 | 40 | 50 |
| 1/2 (13) | 0.622 (16) | 175 (53) | 120 (37) | 97 (30) | 82 (25) | 73 (22) |
| 3/4 (19) | 0.824 (21) | 360 (110) | 250 (76) | 200 (61) | 170 (52) | 151 (46) |
| 1 (25) | 1.049 (27) | 680 (207) | 465 (142) | 375 (114) | 320 (98) | 285 (87) |
| 1-1/4 (32) | 1.380 (35) | 1400 (427) | 950 (290) | 770 (235) | 660 (201) | 580 (177) |
| 1-1/2 (38) | 1.610 (41) | 2100 (640) | 1460 (445) | 1180 (360) | 990 (301) | 900 (274) |

* Cubic ft. of natural gas per hr for gas pressures of 0.5 psig (14-in. w.c.) or less and a pressure drop of 0.5-in. w.c. (based on a 0.60 specific gravity gas). Ref: Chapter 6 current edition of ANSI Z223/NFPA 54.

! WARNING

FIRE OR EXPLOSION HAZARD

Failure to follow this warning could result in personal injury, death, and/or property damage.
 If local codes allow the use of a flexible gas appliance connector, always use a new listed connector. Do not use a connector which has previously served another gas appliance. Black iron pipe shall be installed at the furnace gas control valve and extend a minimum of 2 in. (51 mm) outside the furnace.

! CAUTION

FURNACE OVERHEAT HAZARD

Failure to follow this caution may result in property damage.
 Connect gas pipe to gas valve using a backup wrench to avoid damaging gas controls and burner misalignment.

An accessible manual equipment shutoff valve **MUST** be installed external to furnace casing and within 6 ft. (2 M) of furnace. A 1/8-in. (3 mm) NPT plugged tapping, accessible for test gauge connection, **MUST** be installed immediately upstream of gas supply connection to furnace and downstream of manual equipment shutoff valve.

NOTE: The furnace gas control valve inlet pressure tap connection is suitable to use as test gauge connection providing test pressure **DOES NOT** exceed maximum 0.5 psig (14-in. w.c.) stated on gas control valve (see Fig. 21).

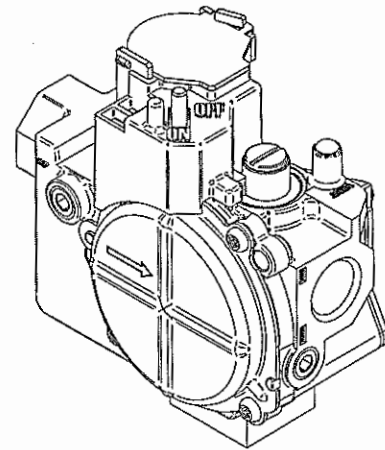

Fig. 21 – Gas Control Valve

A06666

Some installations require gas entry on right side of furnace (as viewed in upflow.) (See Fig. 22).

TOP VIEW OF BURNER AND MANIFOLD ASSEMBLY

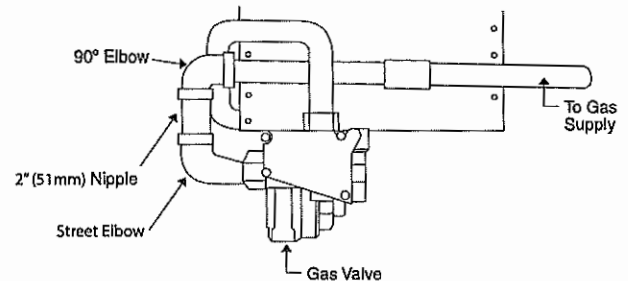

Fig. 22 – Burner and Manifold

A08551

Install a sediment trap in riser leading to furnace (see Fig. 23). Connect a capped nipple into lower end of tee. Capped nipple should extend below level of furnace gas controls. Place a ground joint union between furnace gas control valve and exterior manual equipment gas shutoff valve.
 A 1/8-in. (3 mm) NPT plugged tapping, accessible for test gauge connection, **MUST** be installed immediately upstream of gas supply connection to furnace and downstream of manual equipment shutoff valve.

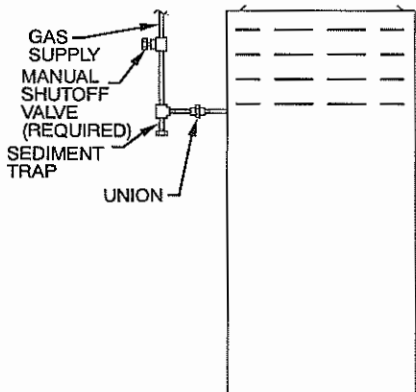

Fig. 23 – Typical Gas Pipe Arrangement

A02035

Piping should be pressure and leak tested in accordance with NFGC in the United States, local, and national plumbing and gas codes before the furnace has been connected. After all connections have been made, purge lines and check for leakage at furnace prior to operating furnace.

If pressure exceeds 0.5 psig (14-in. w.c.), gas supply pipe must be disconnected from furnace and capped before and during supply pipe pressure test. If test pressure is equal to or less than 0.5 psig (14-in. w.c.), turn off electric shutoff switch located on furnace gas control valve and accessible manual equipment shutoff valve before and during supply pipe pressure test. After all connections have been made, purge lines and check for leakage at furnace prior to operating furnace.

The gas supply pressure shall be within the maximum and minimum inlet supply pressures marked on the rating plate with the furnace burners ON and OFF.

ELECTRICAL CONNECTIONS

See Fig. 24 for field wiring diagram showing typical field 115-V wiring. Check all factory and field electrical connections for tightness.

Field-supplied wiring shall conform with the limitations of 63°F (35°C) rise.

! WARNING

ELECTRICAL SHOCK, FIRE OR EXPLOSION HAZARD
 Failure to follow safety warnings could result in dangerous operation, serious injury, death or property damage.
 Improper servicing could result in dangerous operation, serious injury, death or property damage.

- Before servicing, disconnect all electrical power to furnace.
- When servicing controls, label all wires prior to disconnection. Reconnect wires correctly.
- Verify proper operation after servicing.
- Always reinstall access doors after completing service and maintenance.

! WARNING

ELECTRICAL SHOCK HAZARD
 Failure to follow this warning could result in personal injury or death. Blower access panel door switch opens 115-V power to control. No component operation can occur. Do not bypass or close switch with panel removed.

! WARNING

ELECTRICAL SHOCK AND FIRE HAZARD
 Failure to follow this warning could result in personal injury, death, or property damage.
 The cabinet **MUST** have an uninterrupted or unbroken ground according to current edition of NEC NFPA 70 or local codes to minimize personal injury if an electrical fault should occur. This may consist of electrical wire, conduit approved for electrical ground or a listed, grounded power cord (where permitted by local code) when installed in accordance with existing electrical codes. Refer to the power cord manufacturer's ratings for proper wire gauge. Do not use gas piping as an electrical ground.

! CAUTION

FURNACE MAY NOT OPERATE
 Failure to follow this caution may result in intermittent furnace operation.
 Furnace control must be grounded for proper operation or else control will lock out. Control must remain grounded through green/yellow wire routed to gas valve and manifold bracket screw.

115-V Wiring

Verify that the voltage, frequency, and phase correspond to that specified on unit rating plate. Also, check to be sure that service provided by utility is sufficient to handle load imposed by this equipment. Refer to rating plate or Table 6 for equipment electrical specifications.

U.S. Installations: Make all electrical connections in accordance with National Electrical Code (NEC) NFPA 70 and any local codes or ordinances that might apply.

Use a separate, fused branch electrical circuit with a properly sized fuse or circuit breaker for this furnace. See Table 6 for wire size and fuse specifications. A readily accessible means of electrical disconnect must be located within sight of the furnace.

NOTE: Proper polarity must be maintained for 115-V wiring. If polarity is incorrect, control LED status indicator light will flash rapidly and Status code ($\text{H} \cdot \text{I}$) is displayed. The furnace will **NOT** operate.

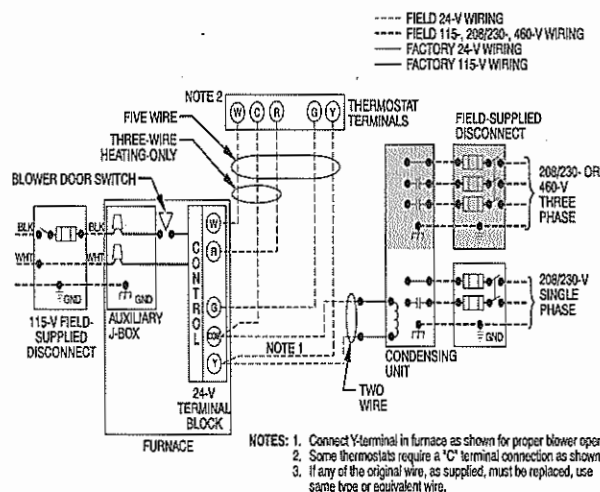

Fig. 24 – Heating and Cooling Application Wiring Diagram with 1-Stage Thermostat

A199079

Table 6 – Electrical Data

| Unit Size | Volts-Hertz-Phase | Operating Voltage* Range | | Maximum Unit Amps | Unit Ampacity† | Minimum Wire Size AWG | Maximum Wire Length‡ Ft. (M) | Maximum Fuse or CKT BKR Amps** |
|-----------|-------------------|--------------------------|---------|-------------------|----------------|-----------------------|------------------------------|--------------------------------|
| | | Maximum | Minimum | | | | | |
| 36045A | 115-60-1 | 127 | 104 | 6.0 | 8.3 | 14 | 44 (13.6) | 15 |
| 42045B | 115-60-1 | 127 | 104 | 7.9 | 10.7 | 14 | 34 (10.6) | 15 |
| 36070A | 115-60-1 | 127 | 104 | 6.0 | 8.3 | 14 | 44 (13.6) | 15 |
| 36070B | 115-60-1 | 127 | 104 | 5.9 | 8.2 | 14 | 45 (13.8) | 15 |
| 48070B | 115-60-1 | 127 | 104 | 10.4 | 13.8 | 14 | 26 (8.2) | 15 |
| 48070C | 115-60-1 | 127 | 104 | 10.4 | 13.8 | 14 | 26 (8.2) | 15 |
| 42090B | 115-60-1 | 127 | 104 | 8.2 | 11.0 | 14 | 34 (10.3) | 15 |
| 48090C | 115-60-1 | 127 | 104 | 8.2 | 11.0 | 14 | 34 (10.3) | 15 |
| 60090C | 115-60-1 | 127 | 104 | 13.9 | 18.1 | 12 | 31 (9.6) | 20 |
| 60110C | 115-60-1 | 127 | 104 | 14.4 | 18.6 | 12 | 30 (9.4) | 20 |
| 60110D | 115-60-1 | 127 | 104 | 11.1 | 14.6 | 14 | 25 (7.7) | 15 |
| 60135D | 115-60-1 | 127 | 104 | 11.0 | 14.4 | 14 | 25 (7.8) | 15 |
| 60155D | 115-60-1 | 127 | 104 | 10.7 | 14.1 | 14 | 26 (8.0) | 15 |

*. Permissible limits of the voltage range at which the unit operates satisfactorily.

†. Unit ampacity = 125 percent of largest operating component's full load amps plus 100 percent of all other potential operating components' (EAC, humidifier, etc.) full load amps.

‡. Length shown is as measured one way along wire path between unit and service panel for maximum 2 percent voltage drop.

** Time-delay type is recommended.

! WARNING

FIRE HAZARD

Failure to follow this warning could result in personal injury, death, or property damage.

Do not connect aluminum wire between disconnect switch and furnace. Use only copper wire (see Fig. 25).

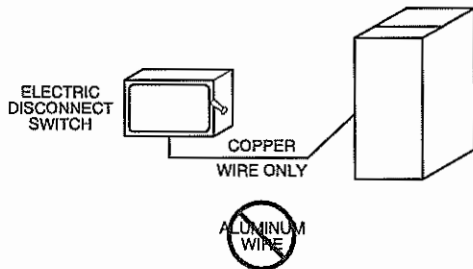

Fig. 25 – Field-Supplied External Electrical Box on Furnace Casing A190279

J-BOX RELOCATION

NOTE: If factory location of J-Box is acceptable, go to next section (ELECTRICAL CONNECTION TO J-BOX).

NOTE: On 14-in. (356 mm) wide casing models, the J-Box shall not be relocated to other side of furnace casing when the vent pipe is routed within the casing.

1. Remove and save two screws holding J-Box.

NOTE: The J-Box cover need not be removed from the J-Box in order to move the J-Box. Do NOT remove green ground screw inside J-Box (see Fig. 26).

2. Cut wire tie on loop in furnace wires attached to J-box.
3. Move J-Box to desired location.
4. Fasten J-Box to casing with two screws removed in Step 1.
5. Route J-Box wires within furnace away from sharp edges, rotating parts and hot surfaces.

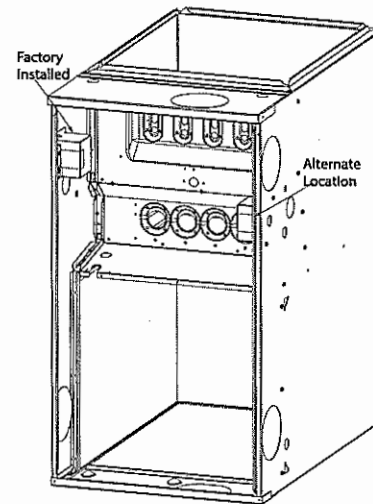

Fig. 26 – Relocating J-Box A10291

**Electrical Connection to J-Box
Electrical Box on Furnace Casing Side**

! WARNING

FIRE OR ELECTRICAL SHOCK HAZARD

Failure to follow this warning could result in personal injury, death, or property damage.

High voltage field connections must be located in J-Box with furnace, or in field supplied external disconnect mounted to furnace.

If field-supplied manual disconnect switch is to be mounted on furnace casing side, select a location where a drill or fastener cannot damage electrical or gas components.

1. Refer to Fig. 27 when installing an electrical box.
2. Select and remove a hole knockout in the casing where the electrical box is to be installed.

NOTE: Check that duct on side of furnace will not interfere with installed electrical box.

3. Remove the desired electrical box hole knockout and position the hole in the electrical box over the hole in the furnace casing.

4. Fasten the electrical box to casing by driving two field supplied screws from inside electrical box into casing steel.

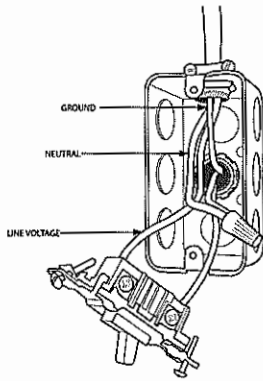

A190278

Fig. 27 – Field-Supplied Electrical Box on Furnace Casing

5. Remove and save two screws holding J-Box.
6. Pull furnace power wires out of 1/2-in. (12 mm) diameter hole in J-Box. Do not loosen wires from strain-relief wire-tie on outside of J-Box.
7. Route furnace power wires through holes in casing and electrical box and into electrical box.
8. Pull field power wires into electrical box.
9. Remove cover from furnace J-Box.
10. Route field ground wire through holes in electrical box and casing, and into furnace J-Box.
11. Reattach furnace J-Box to furnace casing with screws removed in Step 4.
12. Secure field ground wire to J-Box green ground screw.
13. Complete electrical box wiring and installation. Connect line voltage leads (see Fig. 24). Use best practices (NEC in U.S. for wire bushings, strain relief, etc.)
14. Reinstall cover to J-Box. Do not pinch wires between cover and bracket.

Power Cord Installation in Furnace J-Box

NOTE: Power cords must be able to handle the electrical requirements listed in Table 6. Refer to power cord manufacturer’s listings.

1. Remove cover from J-Box.
2. Route listed power cord through 7/8-in. (22 mm) diameter hole in J-Box.
3. Secure power cord to J-Box bracket with a strain relief bushing or a connector approved for the type of cord used.
4. Secure field ground wire to green ground screw on J-Box bracket.
5. Connect line voltage leads (see Fig. 24).
6. Reinstall cover to J-Box. Do not pinch wires between cover and bracket.

BX Cable Installation in Furnace J-Box

1. Remove cover from J-Box.
2. Route BX cable into 7/8-inch diameter hole in J-Box.
3. Secure BX cable to J-Box bracket with connectors approved for the type of cable used.
4. Secure field ground wire to green ground screw on J-Box bracket.

5. Connect line voltage leads (see Fig. 24).
6. Reinstall cover to J-Box. Do not pinch wires between cover and bracket.

24-V Wiring

Make field 24-V connections at the 24-V terminal strip (see Fig. 20). Connect terminal Y for proper cooling operation (see Fig. 28). Use only AWG No. 18, color-coded, copper thermostat wire.

The 24-V circuit contains an automotive-type, 3-amp. fuse located on the control. Any direct shorts during installation, service, or maintenance could cause this fuse to blow. If fuse replacement is required, use **ONLY** a 3-amp. fuse of identical size.

ACCESSORIES

1. **Electronic Air Cleaner (EAC)**
Connect an accessory Electronic Air Cleaner (if used) using 1/4-in female quick connect terminals to the two male 1/4-in quick-connect terminals on the control board marked EAC-1 and EAC-2. The terminals are rated for 115 VAC, 1.0 amps maximum and are energized during blower motor operation (see Fig. 28).
2. **Humidifier (HUM)**
Connect an accessory 24 VAC, 0.5 amp. maximum humidifier (if used) to the 1/4-in male quick-connect HUM terminal and COM-24V screw terminal on the control board thermostat strip. The HUM terminal is energized when the pressure switch closes during a call for heat (see Fig. 28).

NOTE: DO NOT connect furnace control HUM terminal to HUM (humidifier) terminal on humidity sensing thermostat, zone controller or similar device. See humidity sensing thermostat, zone controller, thermostat, or controller manufacturer’s instructions for proper connection.

NOTE: For 24-V & 115-V EAC or Humidifier Accessory details, see Accessory instructions.

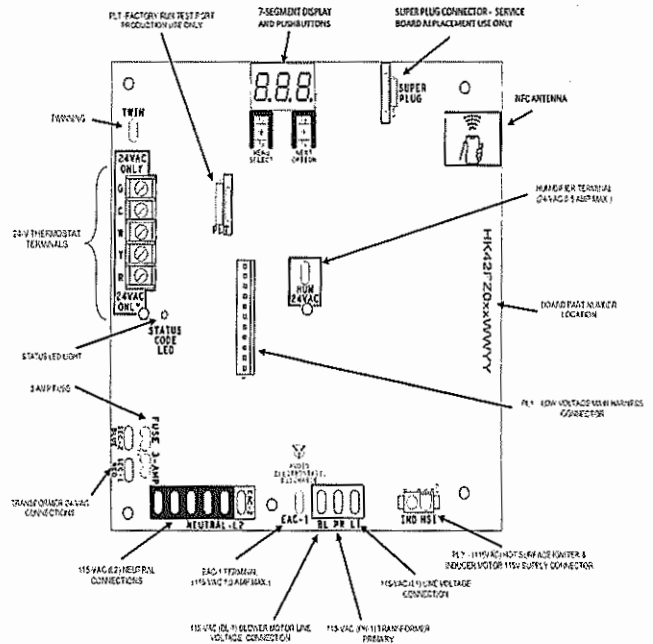
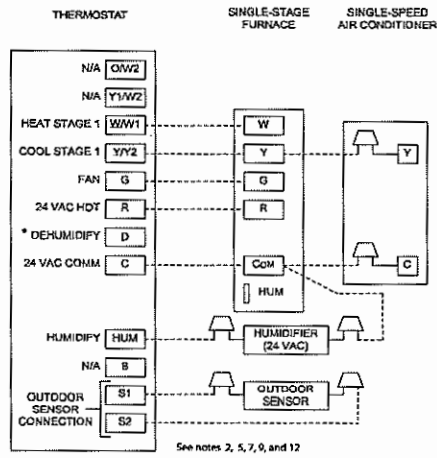
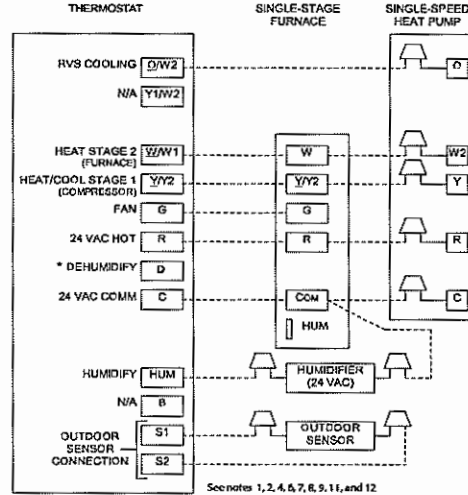

Fig. 28 – Furnace Control

A210192



Single-Stage Furnace with Single-Speed Air Conditioner



Single-Stage Furnace with Single-Speed Heat Pump

Fig. 29 – Thermostat Wiring Diagrams

Notes for thermostat wiring diagrams

1. Heat pump MUST have a high pressure switch for HYBRID HEAT[®] dual fuel applications.
2. Refer to outdoor equipment Installation Instructions for additional information and setup procedure.
3. If the heat pump date code is 1501E or earlier, select the “ZONE” position on the two speed heat pump control. Heat pumps with date code 1601E and later do not have or require a “ZONE” selection.
4. Outdoor Air Temperature Sensor must be attached in all HYBRID HEAT[®] dual fuel applications.
5. Configure the thermostat for air conditioner, installations. Refer to thermostat instructions.
6. Configure the thermostat for heat pump installations. Refer to thermostat instructions.
7. Configure the thermostat for single-stage compressor installations. Refer to thermostat instructions.
8. Configure the thermostat for HYBRID HEAT[®] dual fuel operation installations. Refer to thermostat instructions.
9. NO connection should be made to the furnace HUM terminal when using a thermostat with a 24 volt humidifier output.
10. When connecting humidifier with its own 115 VAC supply use isolation relay between furnace and humidifier.
11. If thermostat has internal control of heat pump balance point, DO NOT SELECT the “FURNACE INTERFACE” or “BALANCE POINT” option on the two-speed heat pump control board. Refer to thermostat instructions.
12. Thermostat signals may vary. Consult thermostat installation instructions for more information.

VENTING

The furnace shall be connected to a listed factory built chimney or vent, or a clay-tile lined masonry or concrete chimney. Venting into an unlined masonry chimney or concrete chimney is prohibited.

When an existing Category I furnace is removed or replaced, the original venting system may no longer be sized to properly vent the attached appliances. An improperly sized Category I venting system could cause the formation of condensate in the furnace and vent, leakage of condensate and combustion products, and spillage of combustion products into the living space.

Vent system or vent connectors may need to be resized. Vent systems or vent connectors, must be sized to approach minimum size as determined using appropriate table found in the NFGC.

General Venting Requirements

Follow all safety codes for proper vent sizing and installation requirements, including local building codes, the current edition of National Fuel Gas Code ANSI Z223.1/NFPA 54 (NFGC), Parts 12 and 13, the local building codes, and furnace and vent manufacturers’ instructions.

These furnaces are design-certified as Category I furnaces in accordance with current edition of ANSI Z21.47/CSA 2.3 and operate with a non-positive vent static pressure to minimize the potential for vent gas leakage. Category I furnaces operate with a flue loss not less than 17 percent to minimize the potential for condensation in the venting system. These furnaces are approved for common venting and multistory venting with other fan assisted or draft hood equipped appliances in accordance with the NFGC, the local building codes, and furnace and vent manufacturers’ instructions.

The following information and warning must be considered in addition to the requirements defined in the NFGC.

1. If a vent (common or dedicated) becomes blocked, the furnace will be shut off by the draft safeguard switch located on the vent elbow.
2. Do not vent this Category I furnace into a single-wall dedicated or common vent. The dedicated or common vent is considered to be the vertical portion of the vent system that terminates outdoors.
3. Vent connectors serving Category I furnaces shall not be connected into any portion of a mechanical draft system operating under positive pressure.
4. Do not vent this appliance with any solid fuel burning appliance.
5. Category I furnaces must be vented vertically or nearly vertically unless equipped with a listed power venter.
6. Do not vent this appliance into an unlined masonry chimney. (Refer to Chimney Inspection Chart, Fig. 30).

A200134

CHIMNEY INSPECTION CHART

For additional requirements refer to the National Fuel Gas Code NFPA 54/ANSI Z223.1 and ANSI/NFPA 211 Chimneys, Fireplaces, Vents, and Solid Fuel Burning Appliances

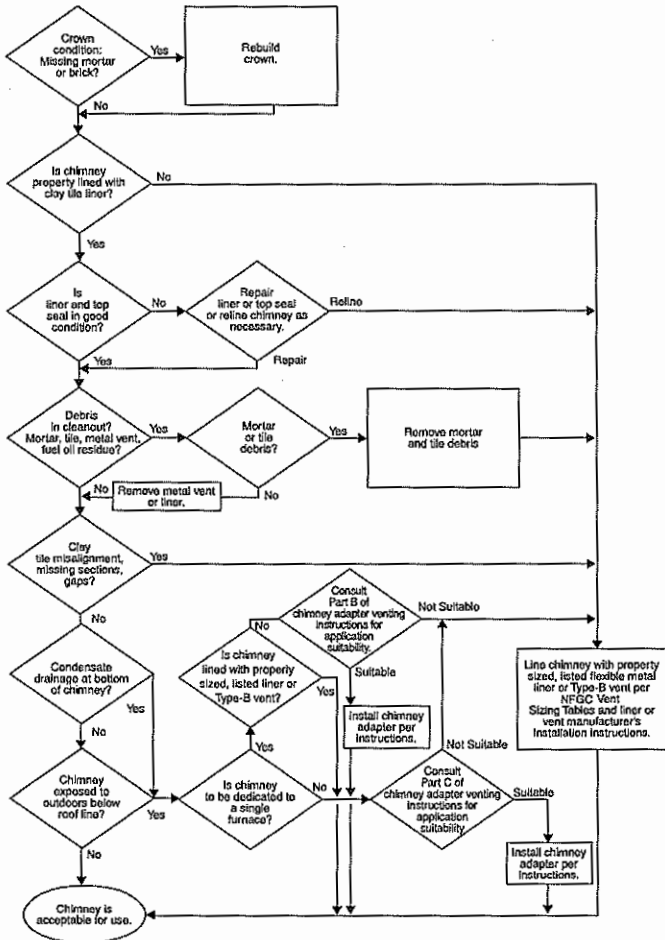

Fig. 30 – Chimney Inspection Chart

A10133

Masonry Chimney Requirements

NOTE: These furnaces are CSA design-certified for use in exterior tile-lined masonry chimneys with a factory accessory Chimney Adapter Kit. Refer to the furnace rating plate for correct kit usage. The Chimney Adapter Kits are for use with **ONLY** furnaces having a Chimney Adapter Kit numbers marked on the furnace rating plate.

If a clay tile-lined masonry chimney is being used and it is exposed to the outdoors below the roof line, relining might be required. Chimneys shall conform to the Standard for Chimneys, Fireplaces, Vents, and Solid Fuel Burning Appliances current edition of ANSI/NFPA 211 and must be in good condition.

U.S.A.— Refer to Sections 13.1.8 and 13.2.20 of the current edition of NFGC NFPA54/ANSI Z223.1 or the authority having jurisdiction to determine whether relining is required. If relining is required, use a properly sized listed metal liner, Type-B vent, or a listed alternative venting design.

NOTE: See the current edition of NFPA54/ANSI Z223.1, 13.1.8 and 13.2.20 regarding alternative venting design and the Exception, which cover installations such as the Chimney Adapter Kits, which are listed for use with these furnaces. See Product Data Sheet for accessory listing.

! WARNING

CARBON MONOXIDE POISONING HAZARD

Failure to follow the steps outlined below for each appliance connected to the venting system being placed into operation could result in carbon monoxide poisoning or death.

The following steps shall be followed for each appliance connected to the venting system being placed into operation, while all other appliances connected to the venting system are not in operation:

- Seal any unused openings in venting system.
- Inspect the venting system for proper size and horizontal pitch, as required in the current edition of National Fuel Gas Code, ANSI Z223.1/NFPA 54 and these instructions. Determine that there is no blockage or restriction, leakage, corrosion and other deficiencies, which could cause an unsafe condition.
- As far as practical, close all building doors and windows and all doors between the space in which the appliance(s) connected to the venting system are located and other spaces of the building.
- Close fireplace dampers.
- Turn on clothes dryers and any appliance not connected to the venting system. Turn on any exhaust fans, such as range hoods and bathroom exhausts, so they are operating at maximum speed. Do not operate a summer exhaust fan.
- Follow the lighting instructions. Place the appliance being inspected into operation. Adjust the thermostat so appliance is operating continuously.
- Test for spillage from draft hood equipped appliances at the draft hood relief opening after 5 minutes of main burner operation. Use the flame of a match or candle.
- If improper venting is observed during any of the above tests, the venting system must be corrected in accordance with the current edition of National Fuel Gas Code, ANSI Z223.1/NFPA 54.
- After it has been determined that each appliance connected to the venting system properly vents when tested as outlined above, return doors, windows, exhaust fans, fireplace dampers and any other gas-fired burning appliance to their previous conditions of use.

The Chimney Adapter Kit is listed alternative venting system for these furnaces. See the kit instructions for complete details.

This furnace is permitted to be vented into a clay tile-lined masonry chimney that is exposed to the outdoors below the roof line, provided:

1. Vent connector is Type-B double-wall, and
2. This furnace is common vented with at least 1 draft hood equipped appliance, and
3. The combined appliance input rating is less than the maximum capacity given in Table 7, and
4. The input rating of each space heating appliance is greater than the minimum input rating given in Table 8 for the local 99% Winter Design Temperature. Chimneys having internal areas greater than 38 square inches require furnace input ratings greater than the input ratings of these furnaces. See footnote at bottom of Table 8, and
5. The authority having jurisdiction approves.

Exterior Masonry Chimney FAN + NAT Installations with Type-B Double Wall Vent Connectors[®] NFPA & AGA

Table 7 – Combined Appliance Maximum Input Rating in Thousands of BTU_h per Hour

| VENT HEIGHT FT. (M) | INTERNAL AREA OF CHIMNEY IN ² (MM ²) | | | |
|------------------------|--|---------------|---------------|---------------|
| | 12 (7741) | 19 (12258) | 28 (18064) | 38 (24516) |
| 6 (1.8) | 74 | 119 | 178 | 257 |
| 8 (2.4) | 80 | 130 | 193 | 279 |
| 10 (3.0) | 84 | 138 | 207 | 299 |
| 15 (4.5) | NR | 152 | 233 | 334 |
| 20 (6.0) | NR | NR | 250 | 368 |
| 30 (9.1) | NR | NR | NR | 404 |

If all of these conditions cannot be met, an alternative venting design shall be used, such as the listed chimney adapter kit with these furnaces, which are listed for use with the kit, a listed chimney-lining system, or a Type-B common vent.

Table 8 – Minimum Allowable Input Rating of Space-Heating Appliance in Thousands of BTU_h per Hour

| VENT HEIGHT FT (M) | INTERNAL AREA OF CHIMNEY IN ² . (MM ²) | | | |
|--|--|---------------|---------------|---------------|
| | 12 (7741) | 19 (12258) | 28 (18064) | 38 (24516) |
| Local 99% Winter Design Temperature: 17 to 26°F (-8 to -3°C) | | | | |
| 6 (1.8) | 0 | 55 | 99 | 141 |
| 8 (2.4) | 52 | 74 | 111 | 154 |
| 10 (3.0) | NR | 90 | 125 | 169 |
| 15 (4.6) | NR | NR | 167 | 212 |
| 20 (6.1) | NR | NR | 212 | 258 |
| 30 (9.1) | NR | NR | NR | 362 |
| Local 99% Winter Design Temperature: 5 to 16°F* (-15 to -9°C) | | | | |
| 6 (1.8) | NR | 78 | 121 | 166 |
| 8 (2.4) | NR | 94 | 135 | 182 |
| 10 (3.0) | NR | 111 | 149 | 198 |
| 15 (4.6) | NR | NR | 193 | 247 |
| 20 (6.1) | NR | NR | NR | 293 |
| 30 (9.1) | NR | NR | NR | 377 |
| Local 99% Winter Design Temperature: -10 to 4°F* (-23 to -16°C) | | | | |
| 6 (1.8) | NR | NR | 145 | 196 |
| 8 (2.4) | NR | NR | 159 | 213 |
| 10 (3.0) | NR | NR | 175 | 231 |
| 15 (4.6) | NR | NR | NR | 283 |
| 20 (6.1) | NR | NR | NR | 333 |
| 30 (9.1) | NR | NR | NR | NR |
| Local 99% Winter Design Temperature: -11°F (-24°C) or lower Not recommended for any vent configuration. | | | | |

* The 99.6% heating db temperatures found in the 1997 or 2001 ASHRAE Fundamentals Handbook, Climatic Design Information chapter, Table 1A (United States) or the 2005 ASHRAE Fundamentals handbook, Climatic Design Information chapter, and the CD-ROM included with the 2005 ASHRAE Fundamentals Handbook.

Inspections before the sale and at the time of installation will determine the acceptability of the chimney or the need for repair and/or (re)lining. Refer to the Fig. 30 to perform a chimney inspection. If the inspection of a previously used tile-lined chimney:

- a. Shows signs of vent gas condensation, the chimney should be relined in accordance with local codes and the authority having jurisdiction. The chimney should be relined with a listed metal liner, Type-B vent, or a listed chimney adapter kit shall be used to reduce condensation. If a condensate drain is required by local code, refer to the current edition of NFGC NFPA54/ANSI Z223.1, Section 12.10 for additional information on condensate drains.
- b. Indicates the chimney exceeds the maximum permissible size in the tables, the chimney should be rebuilt or relined to conform to the requirements of the equipment being installed and the authority having jurisdiction.

A chimney without a clay tile liner, which is otherwise in good condition, shall be rebuilt to conform to current edition of ANSI/NFPA 211 or be lined with a UL listed metal liner or UL listed Type-B vent. Relining with a listed metal liner or Type-B vent is considered to be a vent-in-a-chase.

If a metal liner or Type-B vent is used to line a chimney, no other appliance shall be vented into the annular space between the chimney and the metal liner.

Appliance Application Requirements

Appliance operation has a significant impact on the performance of the venting system. If the appliances are sized, installed, adjusted, and operated properly, the venting system and/or the appliances should not suffer from condensation and corrosion. The venting system and all appliances shall be installed in accordance with applicable listings, standards, and codes.

The furnace should be sized to provide 100 percent of the design heating load requirement plus any margin that occurs because of furnace model size capacity increments. Heating load estimates can be made using approved methods available from Air Conditioning Contractors of America (Manual J); American Society of Heating, Refrigerating, and Air-Conditioning Engineers; or other approved engineering methods. Excessive oversizing of the furnace could cause the furnace and/or vent to fail prematurely. When a metal vent or metal liner is used, the vent must be in good condition and be installed in accordance with the vent manufacturer's instructions.

To prevent condensation in the furnace and vent system, the following precautions must be observed:

1. The return-air temperature must be at least 60°F (16°C)db except for brief periods of time during warm-up from setback at no lower than 55°F (13°C) db or during initial start-up from a standby condition.
2. Adjust the gas input rate per the installation instructions. Low gas input rate causes low vent gas temperatures, causing condensation and corrosion in the furnace and/or venting system. Derating is permitted only for altitudes above 2000 ft. (610 M).
3. Adjust the air temperature rise to the midpoint of the rise range or slightly above. Low air temperature rise can cause low vent gas temperature and potential for condensation problems.
4. Set the thermostat heat anticipator or cycle rate to reduce short cycling.

 **CAUTION**

BURN HAZARD

Failure to follow this caution may cause personal injury. Hot vent pipe is within reach of small children when installed in downflow position. See the following instruction.

Air for combustion must not be contaminated by halogen compounds which include chlorides, fluorides, bromides, and iodides. These compounds are found in many common home products such as

detergent, paint, glue, aerosol spray, bleach, cleaning solvent, salt, and air freshener, and can cause corrosion of furnaces and vents. Avoid using such products in the combustion-air supply. Furnace use during construction of the building could cause the furnace to be exposed to halogen compounds, causing premature failure of the furnace or venting system due to corrosion.

Vent dampers on any appliance connected to the common vent can cause condensation and corrosion in the venting system. Do not use vent dampers on appliances common vented with this furnace.

Additional Venting Requirements

A 4" (101 mm) round vent elbow is supplied with the furnace. A 5-inch (127 mm) or 6-inch (152 mm) vent connector may be required for some model furnaces. A field-supplied 4-inch-to-5-inch (101 - 127 mm) or 4-inch-to-6-inch (101 - 152 mm) sheet metal increaser fitting is required when 5-inch (127 mm) or 6-inch (152 mm) vent connector is used. See Fig. 31 - Fig. 43 Venting Orientation for approved vent configurations.

NOTE: Vent connector length for connector sizing starts at furnace vent elbow. The 4-inch vent elbow is shipped for upflow configuration and may be rotated for other positions. Remove the 3 screws that secure vent elbow to furnace, rotate furnace vent elbow to position desired, reinstall screws. The factory-supplied vent elbow does NOT count as part of the number of vent connector elbows.

! CAUTION

CUT HAZARD

Failure to follow this caution may result in personal injury. Sheet metal parts may have sharp edges or burrs. Use care and wear appropriate protective clothing, safety glasses and gloves when handling parts and servicing furnaces.

The vent connector can exit the furnace through one of 5 locations on the casing.

**Caution!! For the following applications, use the minimum vertical vent heights as specified below.
For all other applications, follow exclusively the National Fuel Gas Code.**

| FURNACE ORIENTATION | VENT ORIENTATION | FURNACE INPUT (BTUH/HR) | MIN. VENT DIAMETER IN. (mm)* | MIN. VERTICAL VENT HEIGHT FT. (M)† |
|---------------------|-----------------------------------|-------------------------|------------------------------|------------------------------------|
| Downflow | Vent elbow left, then up Fig. 35 | 154,000 132,000 110,000 | 5 (127) | 12 (3.6) |
| Horizontal Left | Vent elbow right, then up Fig. 43 | 154,000 132,000 | 5 (127) | 7 (2.1) |
| Horizontal Left | Vent Elbow up Fig. 41 | 154,000 132,000 | 5 (127) | 7 (2.1) |
| Horizontal Left | Vent elbow right Fig. 40 | 154,000 | 5 (127) | 7 (2.1) |
| Downflow | Vent elbow up then left Fig. 31 | 110,000 | 5 (127) | 10 (3.0) |
| Downflow | Vent elbow up, then right Fig. 38 | 110,000 | 5 (127) | 10 (3.0) |

*. 4 in. (102 mm) inside casing or vent guard
†. Including 4 in. (102 mm) vent section(s)

NOTE: All vent configurations must also meet National Fuel Gas Code venting requirements NFGC

1. Attach the single wall vent connector to the furnace vent elbow, and fasten the vent connector to the vent elbow with at least two field-supplied, corrosion-resistant, sheet metal screws located 180° apart.

NOTE: An accessory flue extension is available to extend from the furnace elbow to outside the furnace casing. See Product Data Sheet for accessory listing. If flue extension is used, fasten the flue extension to the vent elbow with at least two field-supplied, corrosion-resistant, sheet metal screws located 180° apart. Fasten the vent connector to the flue extension with at least two field-supplied, corrosion resistant sheet metal screws located 180° apart.

2. Vent the furnace with the appropriate connector (see Fig. 31 - Fig. 43).
3. Determine the correct location of the knockout to be removed.
4. Use a hammer and screwdriver to strike a sharp blow between the tie points and work the slug back and forth until the slug breaks free.

An accessory Vent Guard Kit is REQUIRED for downflow applications where the vent exits through the lower portion of the furnace casing. See Fig. 35 and Product Data Sheet for accessory listing. Refer to the Vent Guard Kit Instructions for complete details.

The horizontal portion of the venting system shall slope upwards not less than 1/4-in. per linear ft. (21 mm/M) from the furnace to the vent and shall be rigidly supported every 5 ft. (2 M) or less with metal hangers or straps to ensure there is no movement after installation.

Sidewall Venting

This furnace is not approved for direct sidewall horizontal venting. Per section 12.4.3 of the current edition of NFPA54/ANSI Z223.1, any listed mechanical venter may be used, when approved by the authority having jurisdiction.

Select the listed mechanical venter to match the BTUh input of the furnace being vented. Follow all manufacturer's installation requirements for venting and termination included with the listed mechanical venter.

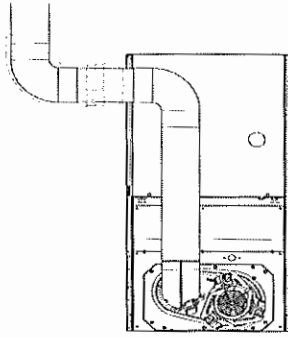

SEE NOTES: 1,2,3,4,5,7,8,9 on the page following these figures

Fig. 31 – Downflow Application-Vent Elbow Up then Left A03210

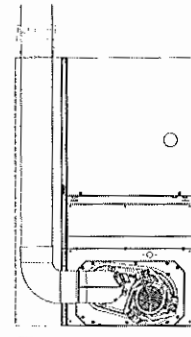

SEE NOTES: 1,2,4,5,6,7,8,9 on the page following these figures

Fig. 35 – Downflow Application-Vent Elbow Left then Up A03207

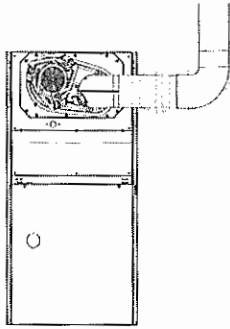

SEE NOTES: 1,2,3,4,7,8,9 on the pages following these figures

Fig. 32 – Upflow Application-Vent Elbow Right A03209

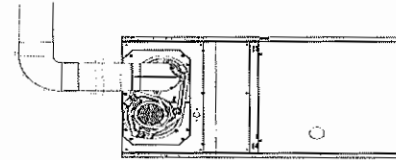

SEE NOTES: 1, 2, 4, 7, 8, 9 on the page following these figures

Fig. 36 – Horizontal Left Application-Vent Elbow Left A03213



SEE NOTES: 1,2,4,5,7,8,9

Fig. 33 – Horizontal Right Application-Vent Elbow Left A02068

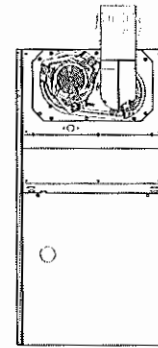

SEE NOTES: 1,2,4,7,8,9 on the page following these figures

Fig. 37 – Upflow Application-Vent Elbow Up A03208

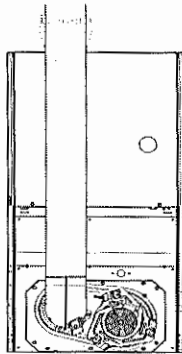

SEE NOTES: 1, 2, 4, 5, 7, 8, 9 on the page following these figures

Fig. 34 – Downflow Application-Vent Elbow Up A03211

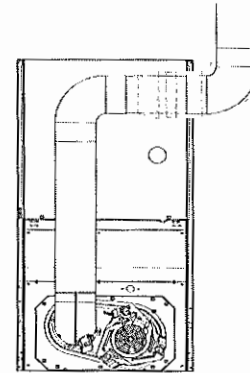

SEE NOTES: 1,2,3,4,5,7,8,9 on the page following these figures.

Fig. 38 – Downflow Application-Vent Elbow Up then Right A03212

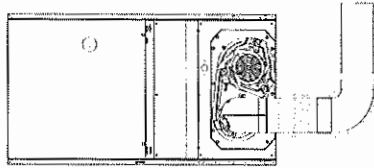

SEE NOTES: 1,2,4,7,8,9 on the page following these figures

Fig. 39 – Horizontal Right Application-Vent Elbow Right A03218

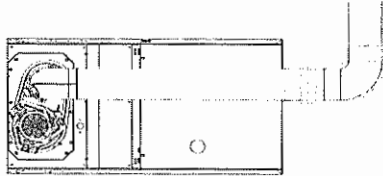

SEE NOTES: 1,2,4,5,7,8,9 on the page following these figures

Fig. 40 – Horizontal Left Application-Vent Elbow Right A03216

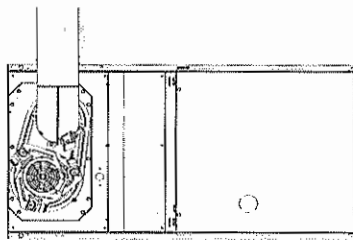

SEE NOTES: 1,2,4,5,7,8,9 on the page following these figures

Fig. 41 – Horizontal Left Application-Vent Elbow Up A03215

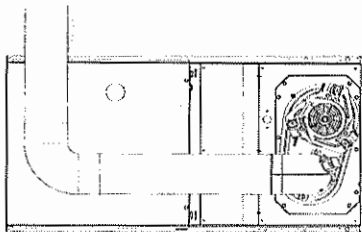

SEE NOTES: 1,2,4,5,7,8,9 on the page following these figures

Fig. 42 – Horizontal Right Application-Vent Elbow Left then Up A03219

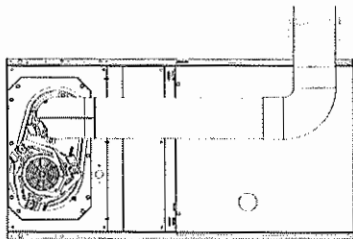

SEE NOTES: 1,2,4,5,7,8,9 on the page following these figures

Fig. 43 – Horizontal Left Application-Vent Elbow Right then Up A03214

Venting notes for Fig. 31 - Fig. 43

1. For common vent, vent connector sizing and vent material: United States-use the NFCC.
2. Immediately increase to 5-inch (127 mm) or 6-inch (152 mm) vent connector outside furnace casing when 5-inch (127 mm) vent connector is required, refer to Note 1 above.
3. Side outlet vent for upflow and downflow installations must use Type B vent immediately after exiting the furnace, except when factory-authorized, Downflow Vent Guard Kit, is used in the downflow position. See Product Data Sheet for accessory listing.
4. Type-B vent where required, refer to Note 1 above.
5. Four-inch single-wall (26 ga. min.) vent must be used inside furnace casing and when the Downflow Vent Guard Kit is used external to the furnace. See Product Data Sheet for accessory listing.
6. Factory-authorized accessory Downflow Vent Guard Kit required in downflow installations with lower vent configuration. See Product Data Sheet for accessory listing.
7. Chimney Adapter Kit may be required for exterior masonry chimney applications. Refer to Chimney Adapter Kit for sizing and complete application details. See Product Data Sheet for accessory listing.
8. Secure vent connector to furnace elbow with (2) corrosion-resistant sheet metal screws, spaced approximately 180° apart.
9. Secure all other single wall vent connector joints with (3) corrosion resistant screws spaced approximately 120° apart. Secure Type-B vent connectors per vent connector manufacturer's recommendations.

AIR DELIVERY - CFM

Table 9 – Air Delivery - CFM (with filter)*

| Unit Size | Airflow Setting | Default Setting | External Static Pressure (in. w.c.) | | | | | | | | | |
|-----------|-----------------|-----------------|-------------------------------------|------|------|------|------|------|------|------|------|-----|
| | | | 0.1 | 0.2 | 0.3 | 0.4 | 0.5 | 0.6 | 0.7 | 0.8 | 0.9 | 1 |
| 36045A | 1 | Constant Fan | 455 | 385 | 320 | 250 | 175 | -- | -- | -- | -- | -- |
| | 2 | | 490 | 425 | 360 | 300 | 225 | 150 | -- | -- | -- | -- |
| | 3 | | 535 | 480 | 415 | 360 | 305 | 230 | 160 | -- | -- | -- |
| | 4 | | 565 | 510 | 450 | 395 | 345 | 285 | 215 | 135 | -- | -- |
| | 5 | | 605 | 555 | 500 | 445 | 390 | 345 | 285 | 215 | 145 | -- |
| | 6 | | 645 | 595 | 545 | 490 | 440 | 395 | 350 | 290 | 225 | 155 |
| | 7 | | 695 | 645 | 600 | 550 | 500 | 455 | 410 | 370 | 310 | 255 |
| | 8 | Heating | 715 | 670 | 625 | 575 | 530 | 485 | 440 | 400 | 355 | 290 |
| | 9 | | 770 | 730 | 685 | 640 | 595 | 555 | 510 | 470 | 430 | 390 |
| | 10 | | 825 | 780 | 740 | 700 | 660 | 615 | 575 | 535 | 500 | 460 |
| | 11 | | 870 | 830 | 795 | 755 | 720 | 680 | 640 | 600 | 560 | 525 |
| | 12 | | 920 | 880 | 845 | 810 | 775 | 735 | 700 | 660 | 625 | 590 |
| | 13 | | 965 | 930 | 895 | 855 | 825 | 790 | 755 | 720 | 685 | 650 |
| | 14 | | 1005 | 970 | 935 | 905 | 875 | 840 | 805 | 770 | 740 | 705 |
| | 15 | | 1055 | 1020 | 990 | 960 | 930 | 895 | 865 | 835 | 800 | 770 |
| | 16 | | 1105 | 1070 | 1040 | 1010 | 980 | 950 | 925 | 895 | 860 | 830 |
| | 17 | | 1125 | 1095 | 1065 | 1035 | 1005 | 975 | 950 | 920 | 890 | 860 |
| | 18 | Cooling | 1210 | 1180 | 1150 | 1120 | 1095 | 1065 | 1040 | 1010 | 980 | 945 |
| 42045B | 1 | Constant Fan | 495 | 425 | 345 | 270 | 210 | 135 | -- | -- | -- | -- |
| | 2 | | 540 | 475 | 400 | 330 | 270 | 205 | 135 | -- | -- | -- |
| | 3 | | 580 | 520 | 455 | 380 | 320 | 260 | 200 | 160 | -- | -- |
| | 4 | | 635 | 575 | 520 | 450 | 385 | 330 | 275 | 215 | 155 | -- |
| | 5 | | 685 | 630 | 570 | 515 | 450 | 390 | 340 | 290 | 235 | 180 |
| | 6 | Heating | 720 | 665 | 615 | 560 | 505 | 445 | 395 | 345 | 295 | 245 |
| | 7 | | 770 | 720 | 665 | 615 | 565 | 505 | 450 | 400 | 355 | 310 |
| | 8 | | 830 | 785 | 735 | 690 | 640 | 590 | 535 | 485 | 440 | 395 |
| | 9 | | 880 | 840 | 790 | 745 | 705 | 660 | 610 | 555 | 510 | 465 |
| | 10 | | 945 | 905 | 860 | 815 | 775 | 735 | 690 | 645 | 595 | 550 |
| | 11 | | 1005 | 965 | 920 | 880 | 840 | 800 | 760 | 725 | 680 | 630 |
| | 12 | | 1060 | 1025 | 985 | 940 | 905 | 865 | 825 | 790 | 750 | 710 |
| | 13 | | 1120 | 1085 | 1050 | 1010 | 970 | 935 | 900 | 865 | 830 | 795 |
| | 14 | | 1170 | 1135 | 1100 | 1065 | 1030 | 995 | 960 | 925 | 890 | 855 |
| | 15 | | 1235 | 1205 | 1170 | 1135 | 1100 | 1065 | 1035 | 1000 | 965 | 915 |
| | 16 | | 1295 | 1265 | 1235 | 1200 | 1170 | 1135 | 1105 | 1075 | 1020 | 930 |
| | 17 | | 1365 | 1335 | 1305 | 1270 | 1240 | 1210 | 1180 | 1125 | 1035 | 930 |
| | 18 | Cooling | 1460 | 1420 | 1375 | 1330 | 1285 | 1235 | 1190 | 1130 | 1035 | 930 |
| 36070A | 1 | Constant Fan | 465 | 400 | 330 | 250 | 180 | 115 | -- | -- | -- | -- |
| | 2 | | 500 | 440 | 370 | 295 | 225 | 165 | 115 | -- | -- | -- |
| | 3 | | 550 | 490 | 430 | 365 | 300 | 235 | 175 | 130 | -- | -- |
| | 4 | | 595 | 540 | 485 | 425 | 355 | 295 | 240 | 185 | 135 | -- |
| | 5 | | 635 | 580 | 530 | 475 | 420 | 355 | 300 | 245 | 195 | 145 |
| | 6 | | 675 | 625 | 575 | 525 | 470 | 410 | 355 | 300 | 250 | 205 |
| | 7 | | 715 | 670 | 625 | 575 | 525 | 475 | 420 | 370 | 320 | 270 |
| | 8 | | 760 | 720 | 675 | 630 | 585 | 535 | 490 | 435 | 390 | 340 |
| | 9 | | 805 | 765 | 725 | 685 | 640 | 595 | 550 | 505 | 455 | 410 |
| | 10 | | 855 | 820 | 780 | 740 | 700 | 660 | 615 | 575 | 530 | 485 |
| | 11 | | 905 | 870 | 835 | 795 | 760 | 720 | 685 | 645 | 600 | 560 |
| | 12 | | 950 | 915 | 880 | 845 | 810 | 775 | 740 | 700 | 665 | 625 |
| | 13 | | 1005 | 970 | 940 | 905 | 870 | 840 | 805 | 770 | 735 | 700 |
| | 14 | | 1055 | 1020 | 990 | 960 | 930 | 895 | 865 | 830 | 800 | 765 |
| | 15 | Heating | 1085 | 1055 | 1025 | 995 | 965 | 935 | 900 | 870 | 840 | 810 |
| | 16 | | 1120 | 1090 | 1060 | 1030 | 1000 | 970 | 940 | 910 | 880 | 850 |
| | 17 | | 1150 | 1120 | 1095 | 1065 | 1035 | 1005 | 975 | 945 | 920 | 890 |
| | 18 | Cooling | 1220 | 1195 | 1170 | 1140 | 1115 | 1090 | 1060 | 1035 | 1005 | 970 |

Table 9 – Air Delivery - CFM (with filter)* (Continued)

| Unit Size | Airflow Setting | Default Setting | External Static Pressure (in. w.c.) | | | | | | | | | | |
|-----------|-----------------|-----------------|-------------------------------------|------|------|------|------|------|------|------|------|------|----|
| | | | 0.1 | 0.2 | 0.3 | 0.4 | 0.5 | 0.6 | 0.7 | 0.8 | 0.9 | 1 | |
| 36070B | 1 | Constant Fan | 475 | 385 | 300 | 220 | 155 | - | -- | -- | -- | -- | -- |
| | 2 | | 515 | 430 | 350 | 275 | 200 | 130 | -- | -- | -- | -- | -- |
| | 3 | | 565 | 490 | 410 | 340 | 270 | 205 | 140 | -- | -- | -- | -- |
| | 4 | | 610 | 540 | 470 | 400 | 335 | 265 | 210 | 150 | -- | -- | -- |
| | 5 | | 655 | 590 | 525 | 455 | 395 | 330 | 270 | 215 | 155 | -- | -- |
| | 6 | | 700 | 635 | 570 | 505 | 445 | 385 | 325 | 270 | 220 | 165 | -- |
| | 7 | | 740 | 685 | 620 | 560 | 500 | 445 | 390 | 335 | 280 | 235 | -- |
| | 8 | | 790 | 735 | 675 | 620 | 565 | 510 | 455 | 400 | 350 | 300 | -- |
| | 9 | | 835 | 785 | 730 | 675 | 620 | 570 | 515 | 465 | 415 | 365 | -- |
| | 10 | | 880 | 830 | 780 | 725 | 675 | 625 | 575 | 525 | 480 | 430 | -- |
| | 11 | | 935 | 890 | 840 | 790 | 740 | 690 | 645 | 595 | 550 | 505 | -- |
| | 12 | | 985 | 940 | 895 | 845 | 800 | 750 | 705 | 665 | 620 | 575 | -- |
| | 13 | | 1035 | 990 | 950 | 900 | 855 | 810 | 770 | 730 | 685 | 640 | -- |
| | 14 | | 1080 | 1040 | 995 | 950 | 910 | 865 | 825 | 785 | 745 | 705 | -- |
| | 15 | Heating | 1120 | 1075 | 1035 | 995 | 950 | 910 | 870 | 830 | 790 | 750 | -- |
| | 16 | | 1175 | 1140 | 1100 | 1060 | 1020 | 980 | 940 | 905 | 865 | 830 | -- |
| | 17 | | 1225 | 1190 | 1155 | 1115 | 1080 | 1040 | 1000 | 965 | 930 | 895 | -- |
| | 18 | Cooling | 1300 | 1265 | 1230 | 1190 | 1160 | 1120 | 1085 | 1050 | 1015 | 980 | -- |
| 48070B | 1 | Constant Fan | 545 | 465 | 385 | 310 | 235 | 155 | -- | -- | -- | -- | -- |
| | 2 | | 605 | 535 | 455 | 385 | 315 | 250 | 175 | -- | -- | -- | -- |
| | 3 | | 665 | 595 | 530 | 460 | 395 | 330 | 270 | 205 | -- | -- | -- |
| | 4 | | 740 | 675 | 615 | 550 | 490 | 430 | 370 | 315 | 255 | 190 | -- |
| | 5 | | 810 | 750 | 690 | 635 | 570 | 515 | 460 | 405 | 355 | 305 | -- |
| | 6 | | 870 | 815 | 760 | 705 | 650 | 595 | 545 | 490 | 440 | 390 | -- |
| | 7 | | 955 | 900 | 850 | 795 | 745 | 695 | 645 | 595 | 545 | 495 | -- |
| | 8 | | 1025 | 975 | 925 | 880 | 835 | 785 | 735 | 685 | 645 | 595 | -- |
| | 9 | | 1095 | 1050 | 1005 | 955 | 915 | 870 | 820 | 770 | 730 | 685 | -- |
| | 10 | | 1175 | 1135 | 1090 | 1045 | 1005 | 960 | 920 | 875 | 830 | 790 | -- |
| | 11 | | 1220 | 1180 | 1135 | 1095 | 1055 | 1015 | 975 | 935 | 890 | 850 | -- |
| | 12 | Heating | 1320 | 1285 | 1245 | 1205 | 1170 | 1130 | 1095 | 1055 | 1015 | 980 | -- |
| | 13 | | 1390 | 1355 | 1315 | 1280 | 1245 | 1210 | 1170 | 1135 | 1100 | 1065 | -- |
| | 14 | | 1475 | 1435 | 1405 | 1370 | 1335 | 1300 | 1265 | 1235 | 1200 | 1165 | -- |
| | 15 | | 1550 | 1520 | 1485 | 1450 | 1415 | 1385 | 1350 | 1320 | 1290 | 1260 | -- |
| | 16 | | 1630 | 1600 | 1570 | 1540 | 1510 | 1480 | 1450 | 1420 | 1390 | 1365 | -- |
| | 17 | | 1705 | 1675 | 1640 | 1615 | 1590 | 1560 | 1535 | 1505 | 1480 | 1455 | -- |
| | 18 | Cooling | 1840 | 1810 | 1775 | 1735 | 1700 | 1660 | 1620 | 1580 | 1540 | 1500 | -- |
| 48070C | 1 | Constant Fan | 590 | 495 | 390 | 290 | 210 | 120 | -- | -- | -- | -- | -- |
| | 2 | | 665 | 580 | 485 | 390 | 300 | 225 | 145 | -- | -- | -- | -- |
| | 3 | | 730 | 655 | 565 | 480 | 385 | 310 | 245 | 170 | -- | -- | -- |
| | 4 | | 820 | 750 | 675 | 595 | 520 | 435 | 360 | 300 | 235 | 165 | -- |
| | 5 | | 875 | 810 | 740 | 665 | 595 | 515 | 435 | 370 | 315 | 250 | -- |
| | 6 | | 950 | 885 | 830 | 760 | 695 | 625 | 550 | 480 | 410 | 360 | -- |
| | 7 | | 1045 | 985 | 930 | 875 | 810 | 750 | 685 | 620 | 555 | 490 | -- |
| | 8 | | 1140 | 1085 | 1030 | 980 | 925 | 865 | 810 | 750 | 695 | 635 | -- |
| | 9 | | 1200 | 1145 | 1095 | 1050 | 1000 | 945 | 885 | 835 | 780 | 730 | -- |
| | 10 | Heating | 1300 | 1250 | 1195 | 1155 | 1110 | 1065 | 1015 | 960 | 910 | 865 | -- |
| | 11 | | 1370 | 1320 | 1275 | 1230 | 1190 | 1150 | 1105 | 1055 | 1005 | 960 | -- |
| | 12 | | 1455 | 1410 | 1365 | 1325 | 1285 | 1245 | 1205 | 1165 | 1115 | 1070 | -- |
| | 13 | | 1535 | 1490 | 1450 | 1415 | 1375 | 1340 | 1305 | 1265 | 1225 | 1185 | -- |
| | 14 | | 1615 | 1575 | 1535 | 1495 | 1460 | 1425 | 1390 | 1355 | 1320 | 1285 | -- |
| | 15 | | 1705 | 1670 | 1635 | 1600 | 1565 | 1535 | 1505 | 1470 | 1435 | 1400 | -- |
| | 16 | | 1775 | 1745 | 1710 | 1680 | 1650 | 1620 | 1590 | 1560 | 1530 | 1505 | -- |
| | 17 | | 1870 | 1840 | 1810 | 1780 | 1750 | 1725 | 1705 | 1670 | 1630 | 1590 | -- |
| | 18 | Cooling | 2025 | 1975 | 1925 | 1875 | 1820 | 1770 | 1725 | 1680 | 1630 | 1585 | -- |

Table 9 – Air Delivery - CFM (with filter)* (Continued)

| Unit Size | Airflow Setting | Default Setting | External Static Pressure (in. w.c.) | | | | | | | | | |
|-----------|-----------------|-----------------|-------------------------------------|------|------|------|------|------|------|------|------|------|
| | | | 0.1 | 0.2 | 0.3 | 0.4 | 0.5 | 0.6 | 0.7 | 0.8 | 0.9 | 1 |
| 42090B | 1 | Constant Fan | 670 | 595 | 485 | 405 | 330 | 245 | 190 | 130 | -- | -- |
| | 2 | | 705 | 635 | 535 | 450 | 380 | 305 | 235 | 180 | 125 | -- |
| | 3 | | 760 | 695 | 625 | 520 | 450 | 380 | 310 | 245 | 195 | 145 |
| | 4 | | 810 | 750 | 685 | 585 | 515 | 450 | 385 | 320 | 260 | 210 |
| | 5 | | 860 | 800 | 745 | 675 | 580 | 510 | 450 | 390 | 325 | 270 |
| | 6 | | 910 | 855 | 800 | 740 | 650 | 580 | 515 | 460 | 400 | 345 |
| | 7 | | 950 | 900 | 850 | 790 | 730 | 640 | 575 | 515 | 465 | 410 |
| | 8 | | 1025 | 975 | 925 | 875 | 820 | 740 | 670 | 615 | 560 | 510 |
| | 9 | | 1075 | 1030 | 985 | 935 | 885 | 835 | 745 | 690 | 630 | 580 |
| | 10 | | 1140 | 1095 | 1050 | 1005 | 960 | 910 | 855 | 775 | 715 | 665 |
| | 11 | 1210 | 1165 | 1125 | 1085 | 1040 | 995 | 950 | 895 | 815 | 760 | |
| | 12 | Heating | 1255 | 1210 | 1170 | 1130 | 1085 | 1045 | 1000 | 955 | 880 | 820 |
| | 13 | | 1280 | 1235 | 1200 | 1160 | 1115 | 1075 | 1030 | 990 | 925 | 855 |
| | 14 | | 1340 | 1300 | 1265 | 1225 | 1185 | 1145 | 1105 | 1065 | 1025 | 965 |
| | 15 | | 1410 | 1370 | 1335 | 1300 | 1265 | 1225 | 1190 | 1150 | 1110 | 1070 |
| | 16 | 1475 | 1440 | 1405 | 1370 | 1335 | 1300 | 1265 | 1225 | 1190 | 1150 | |
| | 17 | 1550 | 1515 | 1480 | 1445 | 1415 | 1380 | 1345 | 1310 | 1270 | 1235 | |
| | 18 | Cooling | 1620 | 1585 | 1555 | 1520 | 1490 | 1460 | 1425 | 1375 | 1315 | 1255 |
| 1 | Constant Fan | | 685 | 585 | 490 | 395 | 315 | 240 | 170 | -- | -- | -- |
| 48090C | 2 | 745 | 660 | 560 | 480 | 390 | 320 | 250 | 185 | -- | -- | |
| | 3 | 810 | 725 | 635 | 550 | 475 | 395 | 325 | 265 | 200 | -- | |
| | 4 | 860 | 785 | 700 | 615 | 540 | 465 | 395 | 335 | 275 | 215 | |
| | 5 | 915 | 845 | 765 | 680 | 610 | 535 | 465 | 400 | 345 | 285 | |
| | 6 | 980 | 910 | 840 | 765 | 690 | 620 | 555 | 490 | 425 | 370 | |
| | 7 | 1040 | 980 | 910 | 840 | 770 | 700 | 635 | 575 | 510 | 450 | |
| | 8 | 1100 | 1040 | 975 | 910 | 840 | 770 | 710 | 650 | 590 | 530 | |
| | 9 | 1170 | 1110 | 1055 | 995 | 930 | 870 | 800 | 745 | 685 | 630 | |
| | 10 | 1225 | 1170 | 1110 | 1055 | 995 | 930 | 865 | 810 | 755 | 700 | |
| | 11 | 1295 | 1245 | 1195 | 1135 | 1085 | 1025 | 970 | 905 | 850 | 795 | |
| | 12 | 1315 | 1265 | 1215 | 1160 | 1110 | 1055 | 1000 | 935 | 880 | 830 | |
| | 13 | Heating | 1350 | 1300 | 1250 | 1195 | 1145 | 1090 | 1035 | 975 | 915 | 865 |
| | 14 | | 1420 | 1375 | 1330 | 1280 | 1230 | 1185 | 1130 | 1075 | 1020 | 960 |
| | 15 | | 1495 | 1455 | 1405 | 1360 | 1315 | 1270 | 1220 | 1170 | 1120 | 1060 |
| | 16 | | 1565 | 1525 | 1480 | 1435 | 1395 | 1350 | 1305 | 1260 | 1210 | 1160 |
| | 17 | 1645 | 1605 | 1565 | 1525 | 1480 | 1435 | 1390 | 1345 | 1300 | 1250 | |
| | 18 | Cooling | 1725 | 1680 | 1645 | 1605 | 1565 | 1520 | 1480 | 1420 | 1340 | 1260 |
| | 1 | | Constant Fan | 770 | 655 | 540 | 430 | 325 | 195 | -- | -- | -- |
| 60090C | 2 | 850 | 745 | 640 | 535 | 435 | 340 | 210 | - | -- | -- | |
| | 3 | 925 | 825 | 725 | 625 | 530 | 435 | 345 | 230 | -- | -- | |
| | 4 | 1030 | 940 | 845 | 755 | 665 | 575 | 490 | 405 | 315 | 185 | |
| | 5 | 1120 | 1040 | 950 | 865 | 780 | 700 | 615 | 540 | 455 | 380 | |
| | 6 | 1210 | 1130 | 1050 | 970 | 895 | 810 | 735 | 655 | 580 | 510 | |
| | 7 | 1285 | 1215 | 1140 | 1065 | 990 | 915 | 840 | 765 | 690 | 620 | |
| | 8 | 1385 | 1320 | 1250 | 1180 | 1110 | 1040 | 975 | 900 | 835 | 765 | |
| | 9 | 1480 | 1415 | 1355 | 1290 | 1215 | 1155 | 1090 | 1025 | 960 | 895 | |
| | 10 | 1570 | 1510 | 1450 | 1390 | 1325 | 1260 | 1200 | 1140 | 1080 | 1015 | |
| | 11 | Heating | 1675 | 1615 | 1560 | 1505 | 1450 | 1390 | 1330 | 1270 | 1210 | 1155 |
| | 12 | | 1775 | 1720 | 1670 | 1615 | 1560 | 1510 | 1450 | 1395 | 1340 | 1285 |
| | 13 | | 1865 | 1815 | 1765 | 1715 | 1660 | 1610 | 1555 | 1500 | 1450 | 1395 |
| | 14 | | 1965 | 1920 | 1875 | 1825 | 1780 | 1730 | 1680 | 1630 | 1580 | 1535 |
| | 15 | 2075 | 2030 | 1985 | 1940 | 1895 | 1845 | 1805 | 1760 | 1710 | 1660 | |
| | 16 | 2170 | 2135 | 2090 | 2050 | 2005 | 1965 | 1925 | 1880 | 1835 | 1790 | |
| | 17 | Cooling | 2270 | 2225 | 2190 | 2150 | 2115 | 2075 | 2035 | 2000 | 1960 | 1920 |
| | 18 | | 2485 | 2445 | 2410 | 2365 | 2315 | 2265 | 2215 | 2160 | 2105 | 2050 |

Table 9 – Air Delivery - CFM (with filter)* (Continued)

| Unit Size | Airflow Setting | Default Setting | External Static Pressure (in. w.c.) | | | | | | | | | |
|-----------|-----------------|-----------------|-------------------------------------|------|------|------|------|------|------|------|------|------|
| | | | 0.1 | 0.2 | 0.3 | 0.4 | 0.5 | 0.6 | 0.7 | 0.8 | 0.9 | 1 |
| 60110C | 1 | Constant Fan | 845 | 730 | 625 | 520 | 420 | 330 | 240 | 135 | -- | -- |
| | 2 | | 920 | 810 | 705 | 610 | 515 | 425 | 345 | 260 | 155 | -- |
| | 3 | | 1025 | 920 | 825 | 735 | 645 | 560 | 475 | 400 | 320 | 245 |
| | 4 | | 1115 | 1015 | 930 | 840 | 760 | 675 | 595 | 520 | 445 | 380 |
| | 5 | | 1235 | 1150 | 1060 | 980 | 900 | 825 | 750 | 675 | 600 | 525 |
| | 6 | | 1340 | 1260 | 1180 | 1100 | 1025 | 955 | 885 | 810 | 740 | 675 |
| | 7 | | 1440 | 1365 | 1290 | 1215 | 1140 | 1070 | 1005 | 940 | 875 | 805 |
| | 8 | | 1530 | 1460 | 1390 | 1320 | 1250 | 1185 | 1115 | 1055 | 995 | 930 |
| | 9 | | 1640 | 1575 | 1510 | 1440 | 1375 | 1310 | 1250 | 1190 | 1130 | 1075 |
| | 10 | | 1745 | 1685 | 1620 | 1555 | 1495 | 1430 | 1370 | 1315 | 1260 | 1205 |
| | 11 | | 1835 | 1780 | 1720 | 1665 | 1605 | 1550 | 1490 | 1435 | 1380 | 1330 |
| | 12 | Heating | 1895 | 1840 | 1785 | 1730 | 1675 | 1615 | 1560 | 1505 | 1455 | 1400 |
| | 13 | | 1950 | 1895 | 1840 | 1785 | 1725 | 1670 | 1615 | 1565 | 1510 | 1460 |
| | 14 | | 2055 | 2005 | 1955 | 1900 | 1845 | 1790 | 1740 | 1690 | 1640 | 1590 |
| | 15 | | 2160 | 2110 | 2065 | 2015 | 1960 | 1910 | 1860 | 1815 | 1765 | 1720 |
| | 16 | Cooling | 2260 | 2210 | 2165 | 2120 | 2070 | 2020 | 1975 | 1930 | 1885 | 1840 |
| | 17 | | 2355 | 2310 | 2265 | 2225 | 2180 | 2135 | 2090 | 2045 | 2005 | 1960 |
| | 18 | | 2520 | 2480 | 2435 | 2395 | 2350 | 2310 | 2255 | 2195 | 2135 | 2080 |
| 60110D | 1 | Constant Fan | 840 | 725 | 615 | 505 | 400 | 310 | 215 | 135 | -- | -- |
| | 2 | | 930 | 825 | 720 | 620 | 520 | 420 | 335 | 250 | 165 | -- |
| | 3 | | 1015 | 915 | 815 | 725 | 630 | 530 | 440 | 360 | 280 | 205 |
| | 4 | | 1095 | 995 | 905 | 815 | 725 | 635 | 540 | 460 | 385 | 310 |
| | 5 | | 1185 | 1090 | 1005 | 915 | 835 | 750 | 665 | 580 | 500 | 430 |
| | 6 | | 1250 | 1160 | 1080 | 1000 | 915 | 840 | 755 | 675 | 595 | 525 |
| | 7 | | 1335 | 1255 | 1175 | 1100 | 1020 | 940 | 870 | 790 | 710 | 635 |
| | 8 | | 1435 | 1355 | 1280 | 1210 | 1140 | 1060 | 990 | 920 | 845 | 780 |
| | 9 | | 1510 | 1435 | 1360 | 1290 | 1225 | 1155 | 1085 | 1015 | 950 | 880 |
| | 10 | | 1600 | 1530 | 1455 | 1390 | 1325 | 1260 | 1190 | 1125 | 1060 | 995 |
| | 11 | | 1685 | 1615 | 1545 | 1480 | 1420 | 1360 | 1295 | 1230 | 1165 | 1110 |
| | 12 | | 1760 | 1695 | 1630 | 1565 | 1505 | 1450 | 1390 | 1330 | 1270 | 1210 |
| | 13 | | 1855 | 1795 | 1730 | 1670 | 1610 | 1560 | 1505 | 1445 | 1385 | 1330 |
| | 14 | | 1945 | 1885 | 1830 | 1770 | 1710 | 1655 | 1605 | 1555 | 1495 | 1445 |
| | 15 | Heating | 2025 | 1970 | 1915 | 1855 | 1800 | 1750 | 1700 | 1650 | 1600 | 1550 |
| | 16 | | 2055 | 2000 | 1945 | 1890 | 1835 | 1785 | 1735 | 1685 | 1635 | 1585 |
| | 17 | | 2125 | 2070 | 2015 | 1965 | 1910 | 1860 | 1815 | 1765 | 1720 | 1670 |
| | 18 | Cooling | 2220 | 2170 | 2115 | 2060 | 2005 | 1960 | 1905 | 1860 | 1810 | 1750 |
| 60135D | 1 | Constant Fan | 760 | 635 | 520 | 405 | 290 | 175 | -- | -- | -- | -- |
| | 2 | | 815 | 700 | 590 | 485 | 370 | 270 | 155 | -- | -- | -- |
| | 3 | | 905 | 795 | 685 | 590 | 490 | 380 | 290 | 185 | -- | -- |
| | 4 | | 975 | 870 | 770 | 680 | 590 | 490 | 395 | 310 | 205 | -- |
| | 5 | | 1025 | 920 | 825 | 740 | 655 | 560 | 460 | 375 | 290 | 195 |
| | 6 | | 1120 | 1025 | 935 | 845 | 770 | 690 | 600 | 505 | 420 | 350 |
| | 7 | | 1205 | 1120 | 1030 | 945 | 870 | 800 | 720 | 635 | 550 | 470 |
| | 8 | | 1285 | 1200 | 1120 | 1040 | 965 | 900 | 830 | 750 | 675 | 590 |
| | 9 | | 1380 | 1305 | 1225 | 1150 | 1075 | 1010 | 950 | 885 | 815 | 735 |
| | 10 | | 1450 | 1380 | 1305 | 1230 | 1160 | 1095 | 1030 | 975 | 910 | 840 |
| | 11 | | 1555 | 1480 | 1415 | 1345 | 1275 | 1210 | 1150 | 1095 | 1045 | 985 |
| | 12 | | 1635 | 1565 | 1500 | 1435 | 1370 | 1310 | 1245 | 1190 | 1140 | 1090 |
| | 13 | | 1710 | 1645 | 1585 | 1525 | 1460 | 1400 | 1340 | 1285 | 1230 | 1185 |
| | 14 | | 1785 | 1725 | 1665 | 1600 | 1545 | 1485 | 1425 | 1375 | 1320 | 1275 |
| | 15 | Heating | 1870 | 1805 | 1750 | 1695 | 1640 | 1580 | 1525 | 1475 | 1420 | 1375 |
| | 16 | | 1940 | 1885 | 1830 | 1780 | 1725 | 1675 | 1620 | 1570 | 1520 | 1475 |
| | 17 | | 2020 | 1965 | 1915 | 1865 | 1815 | 1765 | 1715 | 1665 | 1620 | 1580 |
| | 18 | Cooling | 2125 | 2075 | 2025 | 1975 | 1925 | 1875 | 1825 | 1775 | 1705 | 1640 |

Table 9 – Air Delivery - CFM (with filter)* (Continued)

| Unit Size | Airflow Setting | Default Setting | External Static Pressure (in. w.c.) | | | | | | | | | | |
|-----------|-----------------|-----------------|-------------------------------------|------|------|------|------|------|------|------|------|------|------|
| | | | 0.1 | 0.2 | 0.3 | 0.4 | 0.5 | 0.6 | 0.7 | 0.8 | 0.9 | 1 | |
| 60155D | 1 | Constant Fan | 765 | 645 | 520 | 395 | 290 | 185 | -- | -- | -- | -- | |
| | 2 | | 860 | 750 | 635 | 520 | 410 | 315 | 220 | 145 | -- | -- | |
| | 3 | | 915 | 810 | 705 | 600 | 485 | 385 | 300 | 210 | 135 | -- | |
| | 4 | | 1000 | 895 | 795 | 695 | 595 | 490 | 400 | 320 | 230 | 145 | |
| | 5 | | 1075 | 975 | 880 | 790 | 695 | 595 | 500 | 420 | 335 | 260 | |
| | 6 | | 1170 | 1075 | 985 | 900 | 815 | 730 | 635 | 545 | 470 | 390 | |
| | 7 | | 1260 | 1170 | 1090 | 1010 | 930 | 845 | 765 | 675 | 590 | 510 | |
| | 8 | | 1340 | 1255 | 1180 | 1100 | 1025 | 950 | 870 | 795 | 710 | 625 | |
| | 9 | | 1415 | 1340 | 1260 | 1190 | 1120 | 1045 | 970 | 895 | 815 | 745 | |
| | 10 | | 1505 | 1430 | 1355 | 1290 | 1220 | 1150 | 1080 | 1010 | 945 | 870 | |
| | 11 | | 1575 | 1500 | 1430 | 1365 | 1295 | 1230 | 1165 | 1100 | 1030 | 970 | |
| | 12 | | 1660 | 1590 | 1520 | 1455 | 1395 | 1335 | 1275 | 1210 | 1140 | 1085 | |
| | 13 | | 1735 | 1670 | 1605 | 1545 | 1485 | 1425 | 1365 | 1310 | 1250 | 1185 | |
| | 14 | | 1825 | 1760 | 1700 | 1640 | 1585 | 1530 | 1475 | 1425 | 1365 | 1310 | |
| | 15 | | 1920 | 1860 | 1800 | 1740 | 1685 | 1630 | 1580 | 1530 | 1475 | 1420 | |
| | 16 | Heating | | 2000 | 1945 | 1890 | 1825 | 1775 | 1725 | 1675 | 1625 | 1575 | 1525 |
| | 17 | | | 2085 | 2035 | 1980 | 1925 | 1870 | 1825 | 1780 | 1740 | 1695 | 1650 |
| | 18 | Cooling | | 2205 | 2150 | 2095 | 2040 | 1985 | 1935 | 1885 | 1835 | 1775 | 1720 |

NOTE:

1. A filter is required for each return-air inlet. Airflow performance included 3/4-in. (19 mm) washable filter media such as contained in a factory - authorized accessory filter rack. See accessory list. To determine airflow performance without this filter, assume an additional 0.1 in. w.c. available external static pressure.
2. Adjust the blower airflow setting as necessary for the proper air temperature rise for each installation.
3. Airflows over 1800 CFM require bottom return, two-side return, or bottom and side return. A minimum filter size of 20" x 25" (508 x 635 mm) is required.
4. For upflow applications, air entering from one side into both the side of the furnace and a return air base counts as a side and bottom return
5. The -- entry indicates unstable operating conditions

Table 10 – Airflow Settings

| Unit Size | Default Airflow Settings* | | Designated Airflow Settings | |
|-----------|---------------------------|---------|-----------------------------|--------------|
| | Heating | Cooling | Heating | Constant Fan |
| 36045A | 8 | 18 | (4-12) | (1-7) |
| 42045B | 6 | 18 | (4-12) | (1-7) |
| 36070A | 15 | 18 | (9-16) | (1-7) |
| 36070B | 15 | 18 | (11-17) | (1-8) |
| 48070B | 12 | 18 | (7-13) | (1-4) |
| 48070C | 10 | 18 | (6-14) | (1-8) |
| 42090B | 12 | 18 | (7-16) | (1-9) |
| 48090C | 13 | 18 | (8-16) | (1-6) |
| 60090C | 11 | 17 | (7-14) | (1-9) |
| 60110C | 12 | 16 | (8-15) | (1-9) |
| 60110D | 15 | 18 | (9-17) | (1-6) |
| 60135D | 15 | 18 | (12-16) | (1-7) |
| 60155D | 16 | 18 | (13-17) | (1-2) |

* Setting #1 is the default setting for Constant Fan

FURNACE CONTROL PROGRAMMING AND NAVIGATION

On-Board Control Method

WARNING

ELECTRICAL SHOCK HAZARD

Failure to follow this warning could result in personal injury, or death. Blower access door switch removes 115-V power to control. No component operation can occur unless switch is closed. Caution must be taken when manually closing this switch for service purposes.

Do not tape or permanently allow the door switch to be bypassed. Temporarily depress the door switch with one hand while accessing the service buttons with your other hand. Do not touch uninsulated electrical components.

This furnace model is equipped with an on-board 3-digit LCD display with pushbutton navigation for the adjustment of operating parameters, diagnostics, and service. The control board must be powered to use the display and pushbuttons. Upon startup, the control will alternate displaying the Model Program Number (P_{rn}) and Software Version (μE_r). The control board has been programmed at the factory with a Model Program Number specific to the furnace product number. The correct Model Program Number is shown on the furnace rating plate.

The system's status is displayed after startup or after no control buttons have been pressed for 60 seconds. Status Code LED will also be illuminated or blinking when displaying the system status. The codes which indicate the current operating mode of the system as shown in Table 11.

Table 11 – System Status Display Codes

| Display | Operating Mode | Notes |
|---------|---------------------------------|---|
| rdL | Idle/Standby Mode | No active demands |
| Ht | Heating Mode | Gas Heating active |
| CL | Cooling Mode | Cooling or Heat Pump active |
| HPd | Heat Pump Defrost Mode | Gas Heating cycle active during Heat Pump Defrost cycle |
| CFn | Continuous Fan Mode | Continuous Fan active |
| bLr | Secondary Unit Operating Blower | Only used when control is the secondary furnace of a twinned furnace system and primary furnace is active |
| ##.# | Active Status Code | See Fig. 45 or Furnace Service Label for codes |

Table 12 – Main Menu Options

| Display | Menu Item | Use |
|---------|------------------------------------|---|
| FLt | Last 7 faults that occurred | Faults code menu stores the 7 latest faults in memory. If no faults, None (non) will be displayed. To clear fault history, scroll to Clear (CLr) and press MENU/SELECT. See Fig. 45 or Furnace Service Label for codes. |
| Ht | Heating blower speed | Heating Airflow Setting. Adjust higher to lower Temp. Rise; lower to increase Temp. Rise. See Start-Up Procedures. See Fig. 44 for allowable selections and Table 9 for airflows. |
| CL | Cooling and Heat Pump blower speed | Cooling Airflow Setting. See Fig. 44 for allowable selections and Table 9 for airflows. Refer to cooling or heat pump equipment data for required airflow settings. |
| CFn | Constant Fan blower speed | Constant Fan Airflow Setting. See Fig. 44 for allowable selections and Table 9 for airflows. |
| Hod | Heat OFF Delay | Value shown in seconds. Shorter delays may leave unused heat in ducts. Longer delays may blow cold air at the end of heating demands. |
| Cod | Cool OFF Delay | Value shown in seconds. Shorter delays may leave unused energy in furnace coil. Longer delays may re-evaporate condensate. |
| dir | Direction | Adjusts display orientation 180 degrees between up flow (UPF) and down flow (dnF). |
| Enn | Twining | Primary (Pr) or Secondary (SE) furnace selection. Adjust only if furnace is used in a twinned furnace system. Use of accessory kit required. See kit instructions. |
| nF | Program # and Software | Do NOT program the control board with a Model Program Number different than what is specified on the rating plate. Alternates displaying the saved Model Program Number (Pr) and Software Version (wEr). |
| CLt | Component Test | Use to validate components are functioning as intended. See Component Self-Test instructions in the Start-Up Procedures section. |
| rSE | Reset | Reset settings to Factory Default by selecting Yes (YES). |

The Main Menu provides access to operating parameters of the furnace control including airflows as well as other diagnostics. See Fig. 28 for the location of the pushbuttons. Scroll through Main Menu by pressing MENU/SELECT button. Press NEXT/OPTION to display the current setting of the parameter (value will flash). Additional presses will scroll through setting options. Press MENU/SELECT button to save a new setting and return to the Main Menu. The display will flash three times to confirm a new setting selection has been saved. Fig. 44 shows the flow of the menu and settings. Table 12 provides additional information on parameter adjustment and applicability.

NFC and Supported App Method

This furnace control board is also equipped with NFC (Near Field Communication) technology which allows the adjustment of operating parameters, diagnostics, and service via a field-supplied mobile device with NFC capability and supported mobile app. Remove 115-V power from the furnace control board to use this method. See Fig. 28 for the location of the NFC antenna. Additional instructions and help may be available through the supported mobile app.

Scan the mobile app QR Code on page 1 of this manual for more information and a link to download the mobile app.

Control Board Replacement

If the control board must be replaced, the new board must be programmed with the correct Model Program Number before the furnace will operate. Do NOT program the control board with a Model Program Number different than what is specified on the rating plate. The control may be programmed by either of these approved methods:

1. Use the supported mobile app to flash the model program onto the board using Near Field Communication (NFC). Scan the QR code

on page 1 of this manual for more information and a link to download the mobile app.

2. Use the correct Super Plug (available from distributor / replacement component) for the control board to copy the correct model program onto the new board.

Further details and instructions for these programming methods are provided with the replacement control board.

| | |
|--|----------------|
|  | CAUTION |
| FURNACE OVERHEATING HAZARD | |
| Failure to follow this caution could result in reduced furnace life. | |
| Do NOT program the control board with a Model Program Number different than what is specified on the rating plate. Parameter options will not match design values. | |

Main Menu Flow Chart

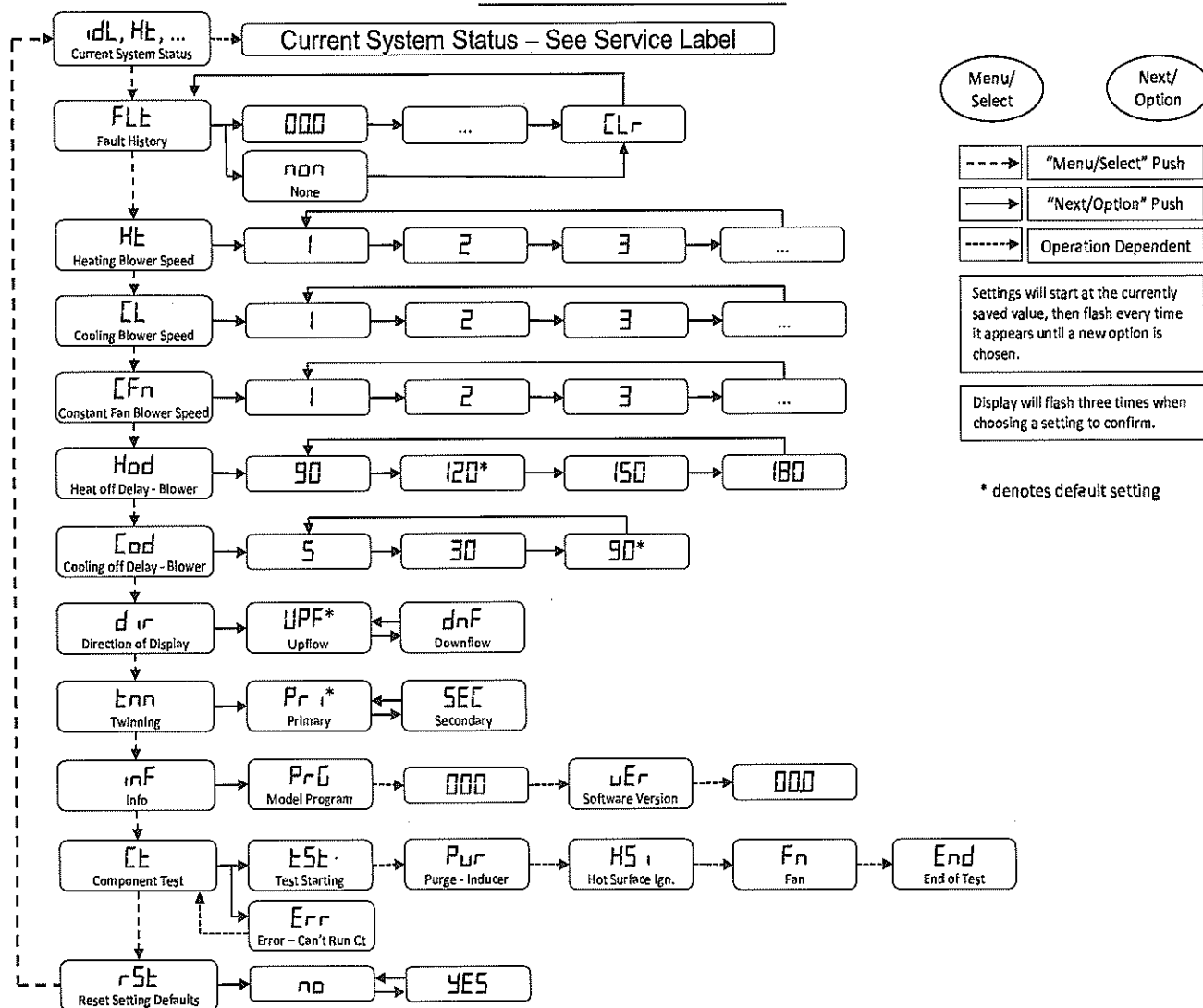

Fig. 44 – 3 Digit Display Flow Chart

SERVICE LABEL

| STATUS CODE TABLE | | | | MENU NAVIGATION | | | | | | | |
|--|-------|---|-------------|--|-------------|-------------|---|--------------|---|-----------------------|--|
| <p>Scan QR code or reference troubleshooting guide in installation manual. The major status code is displayed in the first 2 digits of the display. The minor status code is displayed in the third digit. The major status code is also displayed on the LED indicator through the door with the first digit being the number of short flashes and the second digit being the number of long flashes.</p> | | | | <p>Scroll through main menu by pressing the MENU/SELECT button. Press NEXT/OPTION button to view current setting (will flash on display) and to scroll through setting options. Press MENU/SELECT button to save new setting and return to main menu. The display will flash to confirm setting selection before returning to the main menu.</p> | | | | | | | |
| Major | Minor | Description | Major/Minor | Description | Major/Minor | Description | DISPLAY | DESCRIPTION | DISPLAY | DESCRIPTION | |
| 10 | 1 | L1 polarity fault | | Main program invalid, using backup program to operate. Reprogram control to correct issue. Control still operates normally. | 34 | 1 | Ignition fault - during four consecutive ignition tries. | idL | Idle / Standby Mode | idL, Ht, ... | Current System Status |
| 12 | 1 | W on at power up | | Installer settings corrupted. Try reselecting installer settings, or reprogram control. Control will operate using default installer settings. | 34 | 2 | After successful ignition (flame proven) flame less before heating blower on delay. | Ht | Heating Mode | FLE | Last 7 faults that occurred |
| 13 | 1 | Limit Lockout - switch open longer than 3 minutes in Main Limit circuit | | Wrong program for control used - reprogram control so program matches control used. No heating operation. | 34 | 3 | After successful ignition (flame proven) flame less after heating blower on delay. | CL | Cooling Mode | Ht | Heating Blower speed |
| 14 | 1 | Ignition Lockout after 4 consecutive ignition tries | 25 | If program in furnace control is missing, not recognized, or corrupted. Reprogram control with correct program # as listed on the rating plate. Replace control if issue remains. | 45 | 1 | Control failure - flame circuit fault, memory mismatch or sequence error. | HPd | Heat Pump Defrost Mode | CL | Cooling and Heat Pump Blower speed |
| 14 | 2 | Flame lost 3 times after 70s of heating | 27 | Program in super plug is missing, not recognized, or corrupted. Remove super plug then retry. If still have 27 code, try a different super plug. If still fails, replace control. | 45 | 2 | Control failure - gas valve relay will not close. | CFn | Continuous Fan Mode | CFn | Continuous Fan speed |
| 14 | 3 | Lockout - 7 loss of flame events during a heat request | 31 | Open Main pressure switch. | 46 | 3 | Control failure - EEPROM memory issue. | CFn | Continuous Fan Mode | Hod | Heat OFF delay |
| 21 | 1 | 24VAC sensed on gas valve when shouldn't be | 33 | A switch has opened in the Main Limit circuit. | | 1 | For code 45, cycle power, if code 45 repeats, replace control. | blr | Secondary Unit Operating Blower during CFn, CL, or Ht | Cod | Cool OFF delay |
| 22 | 1 | False flame | | | | 2 | For code 46, cycle power, if code 46 repeats, replace control. | ##.# | Active Status Code | d r | Orientation upflow or downflow |
| 23 | 1 | Stuck Main pressure switch | | | | 3 | For code 46, cycle power, if code 46 repeats, replace control. | | | Enn | Twinning Main or Secondary |
| 24 | 1 | Fuse fault | | | | 1 | Momentary loss of power | | | inF | Program # and Software version |
| 25 | 1 | No program info in micro, no heating operation. | | | | | | | | Ct | Component test |
| 25 | 2 | Corrupted program file, reprogram control using service app or super plug (supplied separately), no heating operation. | | | | | | | | rSt | Reset All Installer Settings to Factory Defaults |
| 25 | 3 | Twinning units are not identical. Ensure furnaces are identical (same program #) when twinning. Main unit will not operate heating. | | | | | | | | | |

Fig. 45 – Service Label

START-UP, ADJUSTMENT, AND SAFETY CHECK

GENERAL

! WARNING

FIRE HAZARD
 Failure to follow this warning could result in personal injury, death and/or property damage.
 This furnace is equipped with manual reset limit switches in the gas control area. The switches open and shut off power to the gas valve if a flame rollout or overheating condition occurs in the gas control area. DO NOT bypass the switches. Correct inadequate combustion air supply problem before resetting the switches.

1. Maintain 115-V wiring and ground. Improper polarity will result in rapid flashing control diagnostic light and Status code (**IdL**) is displayed. The furnace will NOT operate.
2. Make thermostat wire connections at the 24-V terminal block on the furnace control. Failure to make proper connections will result in improper operation (see Fig. 24).
3. Gas supply pressure to the furnace must be greater than 4.5-in. w.c. (0.16 psig) but not exceed 14-in. w.c. (0.5 psig).
4. Check all manual-reset switches for continuity.
5. Install blower compartment door. Door must be in place to operate furnace.
6. Replace outer door.

! CAUTION

CUT HAZARD
 Failure to follow this caution may result in personal injury. Sheet metal parts may have sharp edges or burrs. Use care and wear appropriate protective clothing, safety glasses and gloves when handling parts and servicing furnaces.

Start-Up Procedures

! WARNING

FIRE AND EXPLOSION HAZARD
 Failure to follow this warning could cause personal injury, death and/or property damage.
 Never test for gas leaks with an open flame. Use a commercially available soap solution made specifically for the detection of leaks to check all connections.

1. Purge gas lines after all connections have been made.
2. Check gas lines for leaks.

! WARNING

ELECTRICAL SHOCK HAZARD
 Failure to follow this warning could result in personal injury, or death. Blower access door switch opens 115-V power to control. No component operation can occur unless switch is closed. Caution must be taken. Do not touch uninsulated electrical components when manually closing this switch. for service purposes.

3. To Begin Component Self-Test
 - a. Remove thermostat wire connected to R terminal on control to ensure no thermostat demands are present.
 - b. Temporarily depress blower door switch to power the control board.

! CAUTION

SHOCK HAZARD
 Failure to follow this caution could result in personal injury. Do not tape or permanently allow the door switch to be bypassed. Temporarily depress the door switch with one hand while accessing the service buttons with your other hand. Do not touch uninsulated electrical components.

- c. To initiate the component test sequence, the control must be in (**IdL**) mode. no thermostat demands (W, Y, G). Select component test (**LT**) from menu select buttons to start the component test sequence. Once initiated the furnace control will perform the test sequence as shown in Table 13. Once complete, connect thermostat wire to R terminal on control board and re-install blower door.
4. Operate furnace per instruction on door.
5. Verify furnace shut down by lowering thermostat setting below room temperature.
6. Verify furnace restarts by raising thermostat setting above room temperature.

Table 13 – Test Sequence

| Display | Operating Mode | Function |
|----------------|---------------------|--|
| EST | Test | Confirms start of Component Test mode. |
| PLR | Purge | Inducer ON for 10 seconds before next stage. Inducer remains ON for test duration. |
| HSI | Hot Surface Igniter | Hot Surface Igniter ON for 15 seconds, then OFF. |
| F _n | Fan | Blower ON at 50% torque for 10 seconds, then OFF. |
| End | End Test | All component OFF except for Inducer for 10 seconds. Display returns to IdL . If a thermostat input is detected or fault condition activates during the test sequence, control will abort and display End for 6 seconds. |
| Err | Error | Displayed if component test is not able start. Check for thermostat inputs or faults, and system status is Idle (IdL). |

WIRING DIAGRAM

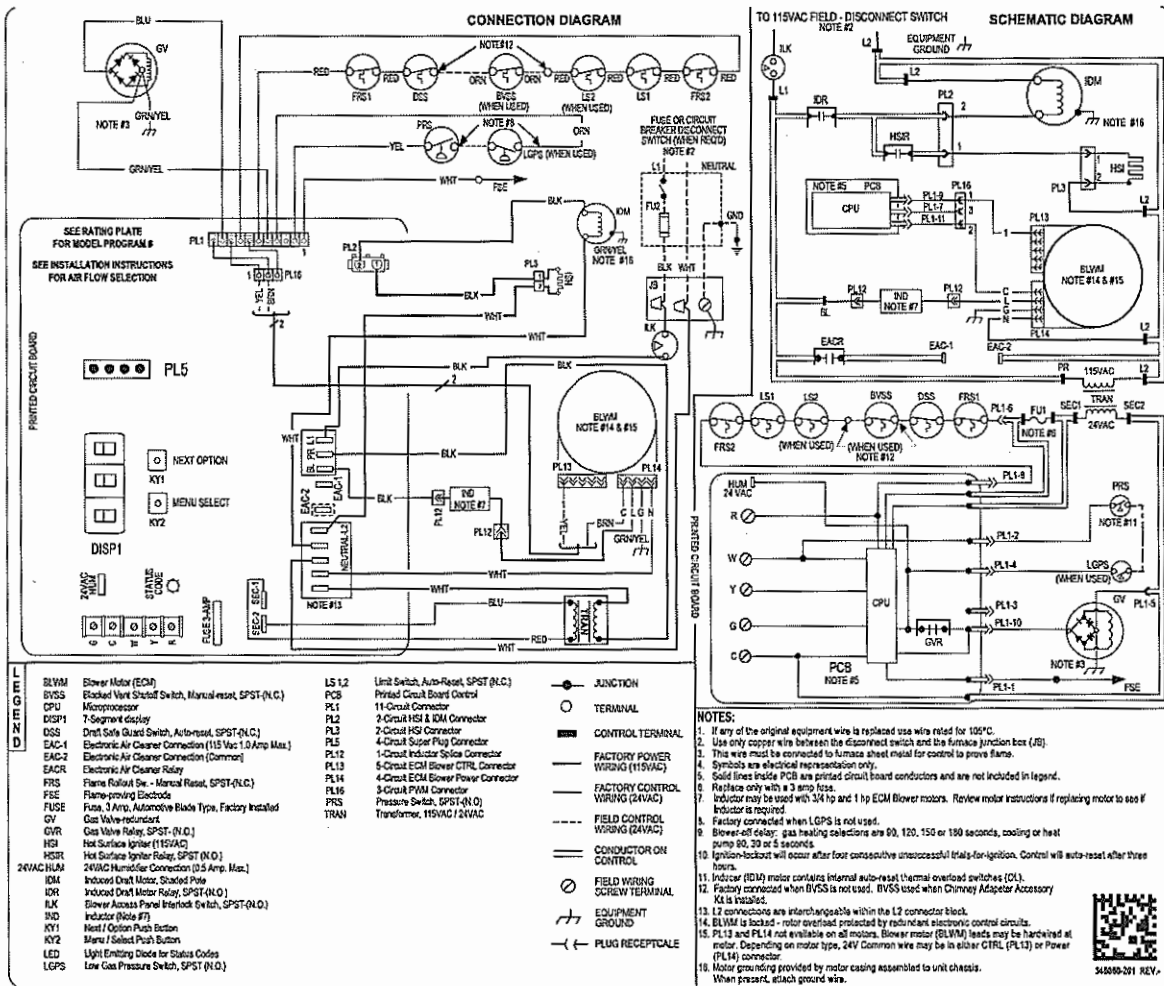

Fig. 46 – Wiring Diagram

Adjustments

Furnace gas input rate on rating plate is for installations at altitudes up to 2000 ft. (610 M). Furnace input rate must be within +/-2 percent of furnace rating plate input.

WARNING

FIRE HAZARD

Failure to follow this warning could result in injury, death and/or property damage. DO NOT bottom out gas valve regulator adjusting screw. This can result in unregulated manifold pressure and result in excess overfire and heat exchanger failures.

- Determine the correct gas input rate. The input rating for altitudes above 2,000 ft. (610 M) must be reduced by 4 percent for each 1,000 ft. (305 M) above sea level. For installations below 2000 ft. (610 M), refer to the unit rating plate. For installations above 2000 ft. (610 M), multiply the input on the rating plate by the de-rate multiplier in Table 14 for the correct input rate.

CAUTION

FURNACE DAMAGE HAZARD

Failure to follow this caution may result in reduced furnace life. DO NOT redrill orifices. Improper drilling (burrs, out-of-round holes, etc.) can cause excessive burner noise and misdirection of burner flames. This can result in flame impingement of heat exchangers, causing failures (see Fig. 47).

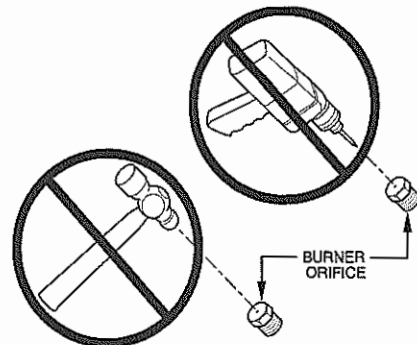

Fig. 47 – Orifice Hole

Table 14 – Altitude Derate Multiplier for U.S.A.

| ALTITUDE (FT. / M) | PERCENT OF DERATE | DERATE MULTIPLIER FACTOR* |
|-------------------------|-------------------------|---------------------------------|
| 0–2000 (0-610) | 0 | 1.00 |
| 2001–3000 (610-914) | 8–12 | 0.90 |
| 3001–4000 (914-1219) | 12–16 | 0.86 |
| 4001–5000 (1219-1524) | 16–20 | 0.82 |
| 5001–6000 (1524-1829) | 20–24 | 0.78 |
| 6001–7000 (1829-2134) | 24–28 | 0.74 |
| 7001–8000 (2134-2438) | 28–32 | 0.70 |
| 8001–9000 (2438-2743) | 32–36 | 0.66 |
| 9001–10,000 (2743-3048) | 36–40 | 0.62 |

*. Derate multiplier factors are based on midpoint altitude for altitude range

2. Determine the correct orifice and manifold pressure adjustment. There are two different orifice and manifold adjustment tables. All models in all positions, except Low NOx models in downflow or horizontal positions, use Table 16 (22,000 BTU_h/Burner). Low NOx models in the downflow or horizontal positions must use Table 17 (21,000 BTU_h/Burner). See input listed on rating plate.
 - a. Obtain average yearly gas heat value (at installed altitude) from local gas supplier.
 - b. Obtain average yearly gas specific gravity from local gas supplier.
 - c. Find installation altitude in Table 16 or Table 17.
 - d. Find closest natural gas heat value and specific gravity in Table 16 or Table 17.
 - e. Follow heat value and specific gravity lines to point of intersection to find orifice size and manifold pressure settings for proper operation.
 - f. Check and verify burner orifice size in furnace. NEVER ASSUME ORIFICE SIZE. ALWAYS CHECK AND VERIFY.

NOTE: If orifice hole appears damaged or it is suspected to have been redrilled, check orifice hole with a numbered drill bit of correct size. Never redrill an orifice. A burr-free and squarely aligned orifice hole is essential for proper flame characteristics.

- g. Replace orifice with correct size if required by Table 14, Table 16, Table 17 and Table 15. Use only factory-supplied orifices. See EXAMPLE 1.

EXAMPLE 1: (0 to 2000 ft. (0 to 610 M) altitude)
 For 22,000 BTU_h per burner application use Table 16.
 Heating value = 1000 BTU_h/cu ft.
 Specific gravity = 0.62
 Therefore: Orifice No. 43*
 Manifold pressure: 3.7-in. w.c.
 *Furnace is shipped with No. 43 orifices.
 In this example all main burner orifices are the correct size and do not need to be changed to obtain proper input rate.

3. Adjust manifold pressure to obtain correct input rate.
 - a. Turn gas valve ON/OFF switch to OFF.
 - b. Remove manifold pressure tap plug from gas valve (see Fig. 21).
 - c. Connect a water column manometer or similar device to manifold pressure tap.
 - d. Turn gas valve ON/OFF switch to ON.
 - e. Manually close blower door switch.
 - f. Set thermostat to call for heat.
 - g. Remove regulator seal cap and turn regulator adjusting screw counterclockwise (out) to decrease input rate of clockwise (in) to increase input rate.

NOTE: DO NOT set manifold pressure less than 3.2-in. w.c. or more than 3.8-in. w.c. for natural gas at sea level. If manifold pressure is

outside this range, change main burner orifices. Refer to Table 14, Table 16, Table 17 and Table 15.

- h. Install regulator seal cap.
- i. Leave manometer or similar device connected and proceed to Step 4.

4. Verify natural gas input rate by clocking meter.

NOTE: Gas valve regulator adjustment cap must be in place for proper input to be clocked.

- a. Turn off all other gas appliances and pilots served by the meter.
- b. Run furnace for 3 minutes in heating operation.
- c. Measure time (in sec) for gas meter to complete 1 revolution and note reading. The 2 or 5 cubic feet dial provides a more accurate measurement of gas flow.
- d. Refer to Table 16 for cubic ft. of gas per hr.
- e. Multiply gas rate (cu ft./hr) by heating value (BTU_h/cu ft.) to obtain input.
- f. If clocked rate does not match required input from Step 1, increase manifold pressure to increase input or decrease manifold pressure to decrease input. Repeat steps b through e until correct input is achieved. Reinstall regulator seal cap on gas valve.

Table 15 – Gas Rate (Cu Ft./Hr.)

| SECONDS FOR 1 REVOLUTION | SIZE OF TEST DIAL | | | SECONDS FOR 1 REVOLUTION | SIZE OF TEST DIAL | | |
|--------------------------|-------------------|----------|----------|--------------------------|-------------------|----------|----------|
| | 1 Cu Ft. | 2 Cu Ft. | 5 Cu Ft. | | 1 Cu Ft. | 2 Cu Ft. | 5 Cu Ft. |
| 10 | 360 | 720 | 1800 | 50 | 72 | 144 | 360 |
| 11 | 327 | 655 | 1636 | 51 | 71 | 141 | 355 |
| 12 | 300 | 600 | 1500 | 52 | 69 | 138 | 346 |
| 13 | 277 | 555 | 1385 | 53 | 68 | 136 | 340 |
| 14 | 257 | 514 | 1286 | 54 | 67 | 133 | 333 |
| 15 | 240 | 480 | 1200 | 55 | 65 | 131 | 327 |
| 16 | 225 | 450 | 1125 | 56 | 64 | 129 | 321 |
| 17 | 212 | 424 | 1059 | 57 | 63 | 126 | 316 |
| 18 | 200 | 400 | 1000 | 58 | 62 | 124 | 310 |
| 19 | 189 | 379 | 947 | 59 | 61 | 122 | 305 |
| 20 | 180 | 360 | 900 | 60 | 60 | 120 | 300 |
| 21 | 171 | 343 | 857 | 62 | 58 | 116 | 290 |
| 22 | 164 | 327 | 818 | 64 | 56 | 112 | 281 |
| 23 | 157 | 313 | 783 | 66 | 54 | 109 | 273 |
| 24 | 150 | 300 | 750 | 68 | 53 | 106 | 265 |
| 25 | 144 | 288 | 720 | 70 | 51 | 103 | 257 |
| 26 | 138 | 277 | 692 | 72 | 50 | 100 | 250 |
| 27 | 133 | 267 | 667 | 74 | 48 | 97 | 243 |
| 28 | 129 | 257 | 643 | 76 | 47 | 95 | 237 |
| 29 | 124 | 248 | 621 | 78 | 46 | 92 | 231 |
| 30 | 120 | 240 | 600 | 80 | 45 | 90 | 225 |
| 31 | 116 | 232 | 581 | 82 | 44 | 88 | 220 |
| 32 | 113 | 225 | 563 | 84 | 43 | 86 | 214 |
| 33 | 109 | 218 | 545 | 86 | 42 | 84 | 209 |
| 34 | 106 | 212 | 529 | 88 | 41 | 82 | 205 |
| 35 | 103 | 206 | 514 | 90 | 40 | 80 | 200 |
| 36 | 100 | 200 | 500 | 92 | 39 | 78 | 196 |
| 37 | 97 | 195 | 486 | 94 | 38 | 76 | 192 |
| 38 | 95 | 189 | 474 | 96 | 38 | 75 | 188 |
| 39 | 92 | 185 | 462 | 98 | 37 | 74 | 184 |
| 40 | 90 | 180 | 450 | 100 | 36 | 72 | 180 |
| 41 | 88 | 176 | 439 | 102 | 35 | 71 | 178 |
| 42 | 86 | 172 | 429 | 104 | 35 | 69 | 173 |
| 43 | 84 | 167 | 419 | 106 | 34 | 68 | 170 |
| 44 | 82 | 164 | 409 | 108 | 33 | 67 | 167 |
| 45 | 80 | 160 | 400 | 110 | 33 | 65 | 164 |
| 46 | 78 | 157 | 391 | 112 | 32 | 64 | 161 |
| 47 | 76 | 153 | 383 | 116 | 31 | 62 | 155 |
| 48 | 75 | 150 | 375 | 120 | 30 | 60 | 150 |
| 49 | 73 | 147 | 367 | | | | |

Table 16 – Orifice Size* and Manifold Pressure (in. w.c.) for Gas Input Rate

(TABULATED DATA BASED ON 22,000 BTUH PER BURNER, DERATED 45%/1000 FT (305M) ABOVE SEA LEVEL)

| ALTITUDE RANGE ft (m) | AVG. GAS HEAT VALUE AT ALTITUDE (Btu/cu ft) | SPECIFIC GRAVITY OF NATURAL GAS | | | | | | | | |
|--|---|---------------------------------|-------------------|-------------|-------------------|-------------|-------------------|-------------|-------------------|-----|
| | | 0.58 | | 0.60 | | 0.62 | | 0.64 | | |
| | | Orifice No. | Manifold Pressure | Orifice No. | Manifold Pressure | Orifice No. | Manifold Pressure | Orifice No. | Manifold Pressure | |
| U.S.A. 0 (0) to 2000 (610) | 900 | 42 | 3.5 | 42 | 3.6 | 42 | 3.7 | 41 | 3.6 | |
| | 925 | 42 | 3.3 | 42 | 3.4 | 42 | 3.5 | 42 | 3.7 | |
| | 950 | 43 | 3.8 | 42 | 3.3 | 42 | 3.4 | 42 | 3.5 | |
| | 975 | 43 | 3.6 | 43 | 3.8 | 42 | 3.2 | 42 | 3.3 | |
| | 1000 | 43 | 3.5 | 43 | 3.6 | 43 | 3.7 | 43 | 3.8 | |
| | 1025 | 43 | 3.3 | 43 | 3.4 | 43 | 3.5 | 43 | 3.6 | |
| | 1050 | 44 | 3.6 | 43 | 3.2 | 43 | 3.4 | 43 | 3.5 | |
| | 1075 | 44 | 3.4 | 44 | 3.5 | 43 | 3.2 | 43 | 3.3 | |
| | 1100 | 44 | 3.3 | 44 | 3.4 | 44 | 3.5 | 43 | 3.2 | |
| | U.S.A. 2001 (611) to 3000 (914) | 800 | 42 | 3.4 | 42 | 3.5 | 42 | 3.6 | 42 | 3.7 |
| 825 | | 42 | 3.2 | 42 | 3.3 | 42 | 3.4 | 42 | 3.5 | |
| 850 | | 43 | 3.7 | 43 | 3.8 | 42 | 3.2 | 42 | 3.3 | |
| 875 | | 43 | 3.5 | 43 | 3.6 | 43 | 3.7 | 43 | 3.8 | |
| 900 | | 43 | 3.3 | 43 | 3.4 | 43 | 3.5 | 43 | 3.6 | |
| 925 | | 43 | 3.1 | 43 | 3.2 | 43 | 3.3 | 43 | 3.4 | |
| 950 | | 43 | 2.9 | 43 | 3.0 | 43 | 3.1 | 43 | 3.2 | |
| 975 | | 43 | 2.8 | 43 | 2.9 | 43 | 3.0 | 43 | 3.1 | |
| 1000 | | 43 | 2.6 | 43 | 2.7 | 43 | 2.8 | 43 | 2.9 | |
| U.S.A. 3001 (915) to 4000 (1219) | | 775 | 42 | 3.2 | 42 | 3.3 | 42 | 3.4 | 42 | 3.5 |
| | 800 | 43 | 3.6 | 43 | 3.8 | 42 | 3.2 | 42 | 3.3 | |
| | 825 | 43 | 3.4 | 43 | 3.5 | 43 | 3.7 | 43 | 3.8 | |
| | 850 | 43 | 3.2 | 43 | 3.3 | 43 | 3.4 | 43 | 3.6 | |
| | 875 | 43 | 3.0 | 43 | 3.1 | 43 | 3.3 | 43 | 3.4 | |
| | 900 | 43 | 2.9 | 43 | 3.0 | 43 | 3.1 | 43 | 3.2 | |
| | 925 | 43 | 2.7 | 43 | 2.8 | 43 | 2.9 | 43 | 3.0 | |
| | 950 | 43 | 2.6 | 43 | 2.7 | 43 | 2.8 | 43 | 2.9 | |
| | U.S.A. 4001 (1220) to 5000 (1524) | 750 | 43 | 3.6 | 43 | 3.8 | 42 | 3.2 | 42 | 3.3 |
| | | 775 | 43 | 3.4 | 43 | 3.5 | 43 | 3.6 | 43 | 3.8 |
| 800 | | 43 | 3.2 | 43 | 3.3 | 43 | 3.4 | 43 | 3.5 | |
| 825 | | 43 | 3.0 | 43 | 3.1 | 43 | 3.2 | 43 | 3.3 | |
| 850 | | 43 | 2.8 | 43 | 2.9 | 43 | 3.0 | 43 | 3.1 | |
| 875 | | 43 | 2.7 | 43 | 2.8 | 43 | 2.9 | 43 | 2.9 | |
| 900 | | 43 | 2.5 | 43 | 2.6 | 43 | 2.7 | 43 | 2.8 | |
| 925 | | 43 | 2.4 | 43 | 2.5 | 43 | 2.6 | 43 | 2.6 | |
| U.S.A. 5001 (1525) to 6000 (1829) | | 725 | 43 | 3.4 | 43 | 3.5 | 43 | 3.6 | 43 | 3.7 |
| | | 750 | 43 | 3.2 | 43 | 3.3 | 43 | 3.4 | 43 | 3.5 |
| | 775 | 43 | 3.0 | 43 | 3.1 | 43 | 3.2 | 43 | 3.3 | |
| | 800 | 43 | 2.8 | 43 | 2.9 | 43 | 3.0 | 43 | 3.1 | |
| | 825 | 43 | 2.6 | 43 | 2.7 | 43 | 2.8 | 43 | 2.9 | |
| | 850 | 43 | 2.5 | 43 | 2.5 | 43 | 2.6 | 43 | 2.7 | |
| | 875 | 43 | 2.3 | 43 | 2.4 | 43 | 2.5 | 43 | 2.6 | |
| | 900 | 43 | 2.2 | 43 | 2.3 | 43 | 2.3 | 43 | 2.4 | |
| | U.S.A. 6001 (1830) to 7000 (2133) | 675 | 43 | 3.4 | 43 | 3.5 | 43 | 3.6 | 43 | 3.7 |
| | | 700 | 43 | 3.1 | 43 | 3.3 | 43 | 3.4 | 43 | 3.5 |
| 725 | | 43 | 2.9 | 43 | 3.0 | 43 | 3.1 | 43 | 3.2 | |
| 750 | | 43 | 2.7 | 43 | 2.8 | 43 | 2.9 | 43 | 3.0 | |
| 775 | | 43 | 2.6 | 43 | 2.7 | 43 | 2.7 | 43 | 2.8 | |
| 800 | | 43 | 2.4 | 43 | 2.5 | 43 | 2.6 | 43 | 2.7 | |
| 825 | | 43 | 2.3 | 43 | 2.3 | 43 | 2.4 | 43 | 2.5 | |
| 850 | | 43 | 2.1 | 43 | 2.2 | 43 | 2.3 | 43 | 2.4 | |

A10180

(TABULATED DATA BASED ON 22,000 BTUH PER BURNER, DERATED 45%/1000 FT (305M) ABOVE SEA LEVEL)

| ALTITUDE RANGE ft (m) | AVG. GAS HEAT VALUE AT ALTITUDE (Btu/cu ft) | SPECIFIC GRAVITY OF NATURAL GAS | | | | | | | | |
|---|---|---------------------------------|-------------------|-------------|-------------------|-------------|-------------------|-------------|-------------------|-----|
| | | 0.58 | | 0.60 | | 0.62 | | 0.64 | | |
| | | Orifice No. | Manifold Pressure | Orifice No. | Manifold Pressure | Orifice No. | Manifold Pressure | Orifice No. | Manifold Pressure | |
| U.S.A. 7001 (2134) to 8000 (2438) | 650 | 43 | 3.1 | 43 | 3.2 | 43 | 3.4 | 43 | 3.5 | |
| | 675 | 43 | 2.9 | 43 | 3.0 | 43 | 3.1 | 43 | 3.2 | |
| | 700 | 43 | 2.7 | 43 | 2.8 | 43 | 2.9 | 43 | 3.0 | |
| | 725 | 43 | 2.5 | 43 | 2.6 | 43 | 2.7 | 43 | 2.8 | |
| | 750 | 43 | 2.4 | 43 | 2.4 | 43 | 2.5 | 43 | 2.6 | |
| | 775 | 43 | 2.2 | 43 | 2.3 | 43 | 2.4 | 43 | 2.4 | |
| | 800 | 43 | 2.1 | 43 | 2.1 | 43 | 2.2 | 43 | 2.3 | |
| | 825 | 48 | 3.7 | 43 | 2.0 | 43 | 2.1 | 43 | 2.2 | |
| | U.S.A. 8001 (2439) to 9000 (2743) | 825 | 43 | 2.9 | 43 | 3.0 | 43 | 3.1 | 43 | 3.2 |
| | | 850 | 43 | 2.7 | 43 | 2.8 | 43 | 2.9 | 43 | 3.0 |
| 875 | | 43 | 2.5 | 43 | 2.6 | 43 | 2.7 | 43 | 2.8 | |
| 900 | | 43 | 2.3 | 43 | 2.4 | 43 | 2.5 | 43 | 2.6 | |
| 925 | | 43 | 2.2 | 43 | 2.2 | 43 | 2.3 | 43 | 2.4 | |
| 950 | | 43 | 2.0 | 43 | 2.1 | 43 | 2.2 | 43 | 2.2 | |
| 975 | | 48 | 3.6 | 48 | 3.7 | 43 | 2.0 | 43 | 2.1 | |
| U.S.A. 9001 (2744) to 10000 (3048) | | 800 | 43 | 2.7 | 43 | 2.8 | 43 | 2.9 | 43 | 3.0 |
| | | 825 | 43 | 2.5 | 43 | 2.6 | 43 | 2.6 | 43 | 2.7 |
| | | 850 | 43 | 2.3 | 43 | 2.4 | 43 | 2.4 | 43 | 2.5 |
| | 875 | 43 | 2.1 | 43 | 2.2 | 43 | 2.3 | 43 | 2.3 | |
| | 900 | 48 | 3.7 | 43 | 2.0 | 43 | 2.1 | 43 | 2.2 | |
| | 925 | 48 | 3.5 | 48 | 3.6 | 48 | 3.7 | 43 | 2.0 | |

* Orifice numbers shown in BOLD are factory-installed.

A10180A

Table 17 – Orifice Size* And Manifold Pressure (in. w.c.) for Gas Input Rate

(TABULATED DATA BASED ON 21,000 BTUH PER BURNER, DERATED 4%/1000 FT (305M) ABOVE SEA LEVEL)

| ALTITUDE RANGE ft (m) | AVG. GAS HEAT VALUE AT ALTITUDE (Btu/cu ft) | SPECIFIC GRAVITY OF NATURAL GAS | | | | | | | | |
|---|---|---------------------------------|-------------------|-------------|-------------------|-------------|-------------------|-------------|-------------------|-----|
| | | 0.58 | | 0.60 | | 0.62 | | 0.64 | | |
| | | Orifice No. | Manifold Pressure | Orifice No. | Manifold Pressure | Orifice No. | Manifold Pressure | Orifice No. | Manifold Pressure | |
| U.S.A. 0 (0) to 2000 (610) 1100 | 900 | 42 | 3.2 | 42 | 3.3 | 42 | 3.4 | 42 | 3.5 | |
| | 925 | 43 | 3.7 | 43 | 3.8 | 42 | 3.2 | 42 | 3.3 | |
| | 950 | 43 | 3.5 | 43 | 3.6 | 43 | 3.7 | 43 | 3.8 | |
| | 975 | 43 | 3.3 | 43 | 3.4 | 43 | 3.5 | 43 | 3.7 | |
| | 1000 | 44 | 3.5 | 43 | 3.3 | 43 | 3.4 | 43 | 3.5 | |
| | 1025 | 44 | 3.4 | 44 | 3.6 | 43 | 3.2 | 43 | 3.3 | |
| | 1050 | 44 | 3.3 | 44 | 3.4 | 44 | 3.5 | 44 | 3.2 | |
| | 1075 | 45 | 3.8 | 44 | 3.2 | 44 | 3.3 | 44 | 3.4 | |
| | 1100 | 46 | 3.6 | 45 | 3.7 | 44 | 3.2 | 44 | 3.3 | |
| | U.S.A. 2001 (611) to 3000 (914) 925 | 800 | 43 | 3.8 | 42 | 3.2 | 42 | 3.3 | 42 | 3.4 |
| 825 | | 43 | 3.5 | 43 | 3.7 | 43 | 3.8 | 42 | 3.2 | |
| 850 | | 43 | 3.3 | 43 | 3.5 | 43 | 3.6 | 43 | 3.7 | |
| 875 | | 43 | 3.2 | 43 | 3.3 | 43 | 3.4 | 43 | 3.5 | |
| 900 | | 43 | 3.0 | 43 | 3.1 | 43 | 3.2 | 43 | 3.3 | |
| 925 | | 43 | 2.9 | 43 | 2.9 | 43 | 3.0 | 43 | 3.1 | |
| 950 | | 43 | 2.7 | 43 | 2.8 | 43 | 2.9 | 43 | 2.9 | |
| 975 | | 43 | 2.5 | 43 | 2.6 | 43 | 2.7 | 43 | 2.8 | |
| 1000 | | 43 | 2.4 | 43 | 2.5 | 43 | 2.6 | 43 | 2.7 | |
| U.S.A. 3001 (915) to 4000 (1219) 925 | | 775 | 43 | 3.5 | 43 | 3.7 | 43 | 3.8 | 42 | 3.2 |
| | 800 | 43 | 3.3 | 43 | 3.4 | 43 | 3.5 | 43 | 3.7 | |
| | 825 | 43 | 3.1 | 43 | 3.2 | 43 | 3.3 | 43 | 3.4 | |
| | 850 | 43 | 2.9 | 43 | 3.0 | 43 | 3.1 | 43 | 3.2 | |
| | 875 | 43 | 2.8 | 43 | 2.9 | 43 | 3.0 | 43 | 3.1 | |
| | 900 | 43 | 2.6 | 43 | 2.7 | 43 | 2.8 | 43 | 2.9 | |
| | 925 | 43 | 2.5 | 43 | 2.6 | 43 | 2.7 | 43 | 2.7 | |
| | 950 | 43 | 2.4 | 43 | 2.4 | 43 | 2.5 | 43 | 2.6 | |
| | U.S.A. 4001 (1220) to 5000 (1524) 925 | 750 | 43 | 3.3 | 43 | 3.4 | 43 | 3.5 | 43 | 3.6 |
| | | 775 | 43 | 3.1 | 43 | 3.2 | 43 | 3.3 | 43 | 3.4 |
| 800 | | 43 | 2.9 | 43 | 3.0 | 43 | 3.1 | 43 | 3.2 | |
| 825 | | 43 | 2.7 | 43 | 2.8 | 43 | 2.9 | 43 | 3.0 | |
| 850 | | 43 | 2.6 | 43 | 2.7 | 43 | 2.8 | 43 | 2.8 | |
| 875 | | 43 | 2.4 | 43 | 2.5 | 43 | 2.6 | 43 | 2.7 | |
| 900 | | 43 | 2.3 | 43 | 2.4 | 43 | 2.5 | 43 | 2.5 | |
| 925 | | 43 | 2.2 | 43 | 2.2 | 43 | 2.3 | 43 | 2.4 | |
| U.S.A. 5001 (1525) to 6000 (1828) 825 | | 725 | 43 | 3.1 | 43 | 3.2 | 43 | 3.3 | 43 | 3.4 |
| | | 750 | 43 | 2.9 | 43 | 3.0 | 43 | 3.1 | 43 | 3.2 |
| | 775 | 43 | 2.7 | 43 | 2.8 | 43 | 2.9 | 43 | 3.0 | |
| | 800 | 43 | 2.5 | 43 | 2.6 | 43 | 2.7 | 43 | 2.8 | |
| | 825 | 43 | 2.4 | 43 | 2.5 | 43 | 2.5 | 43 | 2.6 | |
| | 850 | 43 | 2.2 | 43 | 2.3 | 43 | 2.4 | 43 | 2.5 | |
| | 875 | 43 | 2.1 | 43 | 2.2 | 43 | 2.3 | 43 | 2.3 | |
| | 900 | 43 | 2.0 | 43 | 2.1 | 43 | 2.1 | 43 | 2.2 | |
| | U.S.A. 6001 (1830) to 7000 (2133) 825 | 675 | 43 | 3.1 | 43 | 3.2 | 43 | 3.3 | 43 | 3.4 |
| | | 700 | 43 | 2.9 | 43 | 3.0 | 43 | 3.1 | 43 | 3.2 |
| 725 | | 43 | 2.7 | 43 | 2.8 | 43 | 2.9 | 43 | 2.9 | |
| 750 | | 43 | 2.5 | 43 | 2.6 | 43 | 2.7 | 43 | 2.8 | |
| 775 | | 43 | 2.3 | 43 | 2.4 | 43 | 2.5 | 43 | 2.6 | |
| 800 | | 43 | 2.2 | 43 | 2.3 | 43 | 2.3 | 43 | 2.4 | |
| 825 | | 43 | 2.1 | 43 | 2.1 | 43 | 2.2 | 43 | 2.3 | |
| 850 | | 48 | 3.7 | 43 | 2.0 | 43 | 2.1 | 43 | 2.1 | |

A10181

(TABULATED DATA BASED ON 21,000 BTUH PER BURNER, DERATED 4%/1000 FT (305M) ABOVE SEA LEVEL)

| ALTITUDE RANGE ft (m) | AVG. GAS HEAT VALUE AT ALTITUDE (Btu/cu ft) | SPECIFIC GRAVITY OF NATURAL GAS | | | | | | | | |
|--|---|---------------------------------|-------------------|-------------|-------------------|-------------|-------------------|-------------|-------------------|-----|
| | | 0.58 | | 0.60 | | 0.62 | | 0.64 | | |
| | | Orifice No. | Manifold Pressure | Orifice No. | Manifold Pressure | Orifice No. | Manifold Pressure | Orifice No. | Manifold Pressure | |
| U.S.A. 7001 (2134) to 8000 (2436) 825 | 650 | 43 | 2.9 | 43 | 3.0 | 43 | 3.1 | 43 | 3.2 | |
| | 675 | 43 | 2.7 | 43 | 2.7 | 43 | 2.8 | 43 | 2.9 | |
| | 700 | 43 | 2.5 | 43 | 2.6 | 43 | 2.6 | 43 | 2.7 | |
| | 725 | 43 | 2.3 | 43 | 2.4 | 43 | 2.5 | 43 | 2.5 | |
| | 750 | 43 | 2.1 | 43 | 2.2 | 43 | 2.3 | 43 | 2.4 | |
| | 775 | 43 | 2.0 | 43 | 2.1 | 43 | 2.2 | 43 | 2.2 | |
| | 800 | 48 | 3.6 | 48 | 3.7 | 43 | 2.0 | 43 | 2.1 | |
| | 825 | 48 | 3.3 | 48 | 3.5 | 48 | 3.6 | 48 | 3.7 | |
| | U.S.A. 8001 (2439) to 9000 (2743) 775 | 625 | 43 | 2.7 | 43 | 2.7 | 43 | 2.8 | 43 | 2.9 |
| | | 650 | 43 | 2.5 | 43 | 2.5 | 43 | 2.6 | 43 | 2.7 |
| 675 | | 43 | 2.3 | 43 | 2.4 | 43 | 2.4 | 43 | 2.5 | |
| 700 | | 43 | 2.1 | 43 | 2.2 | 43 | 2.3 | 43 | 2.3 | |
| 725 | | 48 | 3.7 | 43 | 2.0 | 43 | 2.1 | 43 | 2.2 | |
| 750 | | 48 | 3.5 | 48 | 3.6 | 48 | 3.7 | 43 | 2.0 | |
| 775 | | 49 | 3.8 | 48 | 3.4 | 48 | 3.5 | 48 | 3.6 | |
| U.S.A. 9001 (2744) to 10000 (3048) 725 | | 600 | 43 | 2.4 | 43 | 2.5 | 43 | 2.6 | 43 | 2.7 |
| | | 625 | 43 | 2.3 | 43 | 2.3 | 43 | 2.4 | 43 | 2.5 |
| | | 650 | 43 | 2.1 | 43 | 2.2 | 43 | 2.2 | 43 | 2.3 |
| | 675 | 48 | 3.8 | 48 | 3.8 | 43 | 2.1 | 43 | 2.1 | |
| | 700 | 48 | 3.4 | 48 | 3.5 | 48 | 3.6 | 48 | 3.7 | |
| | 725 | 49 | 3.7 | 49 | 3.8 | 48 | 3.4 | 48 | 3.5 | |

* Orifice numbers shown in BOLD are factory-installed.

A10181A

Adjust Temperature Rise

5. Set temperature rise. The furnace must operate within the temperature rise ranges specified on the furnace rating plate. Do not exceed temperature rise range specified on unit rating plate. Determine the temperature rise as follows:

! CAUTION

FURNACE DAMAGE HAZARD

Failure to follow this caution may result in:

- Overheating the heat exchangers or condensing flue gases in heat exchanger areas not designed for condensate.
- Shortened furnace life
- Component damage.

Temperature rise must be within limits specified on furnace rating plate. Recommended operation is at midpoint of rise range or slightly above.

NOTE: Blower access door must be installed when taking temperature rise reading. Leaving blower access door off will result in incorrect temperature measurements.

- Place thermometers in return and supply ducts as close to furnace as possible. Be sure thermometers do not see radiant heat from heat exchangers. Radiant heat affects temperature rise readings. This practice is particularly important with straight-run ducts.
- When thermometer readings stabilize, subtract return-air temperature from supply-air temperature to determine air temperature rise.

NOTE: If the temperature rise is outside this range, first check:

- Gas input for heating operation.
- Derate for altitude if applicable.
- Return and supply ducts for excessive restrictions causing static pressures greater than 0.50-in. w.c.

! WARNING

ELECTRICAL SHOCK HAZARD

Failure to follow this warning could result in personal injury or death. Blower access door switch opens 115-V power to control. No component operation can occur unless switch is closed. Caution must be taken when manually closing this switch.

- Adjust air temperature rise by adjusting blower speed. Increase blower speed to reduce temperature rise. Decrease blower speed to increase temperature rise
- Turn thermostat down below room temperature and remove blower access door.
- Refer to the **FURNACE CONTROL PROGRAMMING AND NAVIGATION** section of this manual for instructions on adjusting the blower speed.
- Repeat steps a through e until temperature rise is within range on rating plate.
- When correct input rate and temperature rise is achieved, turn gas valve ON/OFF switch to OFF.

! WARNING

FIRE HAZARD

Failure to follow this warning could result in personal injury, death, and/or property damage. Reinstall manifold pressure tap plug in gas valve to prevent gas leak.

- Remove manometer or similar device from gas valve.
- Reinstall manifold pressure tap plug in gas valve.

! WARNING

FURNACE OVERHEATING HAZARD

Failure to follow this caution may result in reduced furnace life. Recheck temperature rise. It must be within limits specified on the rating plate. Recommended operation is at the mid-point of rise range or slightly above.

6. Adjust heating blower-OFF delay. The blower-OFF delay has four adjustable settings from 90 sec to 180 sec. Refer to the **FURNACE CONTROL PROGRAMMING AND NAVIGATION** section of this manual for instructions. Factory off delay setting is 120 sec.
7. Set airflow CFM for cooling. See Table 9-Air Delivery-CFM (with filter).
8. Adjust cooling blower-OFF delay. Refer to the **FURNACE CONTROL PROGRAMMING AND NAVIGATION** section of this manual for instructions.

Check Safety Controls

The flame sensor, gas valve, and pressure switch were all checked in the Start-up procedure section as part of normal operation.

1. Check Main Limit Switch(es)

This control shuts off combustion control system and energizes air-circulating blower motor, if furnace overheats. By using this method to check limit control, it can be established that limit is functioning properly and will operate if there is a restricted duct system or motor failure. If limit control does not function during this test, cause must be determined and corrected.

 - a. Run furnace for at least 5 minutes.
 - b. Gradually block off return air with a piece of cardboard or sheet metal until the limit trips.
 - c. Unblock return air to permit normal circulation.
 - d. Burners will re-light when furnace cools down.
2. Check draft safeguard switch.

The purpose of this control is to cause the safe shutdown of the furnace during certain blocked vent conditions.

 - a. Verify vent pipe is cool to the touch.
 - b. Disconnect power to furnace and remove vent connector from furnace vent elbow.
 - c. Restore power to furnace and set room thermostat above room temperature.
 - d. After normal start-up, allow furnace to operate for 2 minutes, then block vent elbow in furnace 80 percent of vent area with a piece of flat sheet metal.
 - e. Furnace should cycle off within 2 minutes. If gas does not shut off within 2 minutes, determine reason draft safeguard switch did not function properly and correct condition.
 - f. Remove blockage from furnace vent elbow.
 - g. Switch will auto-reset when it cools.
 - h. Re-install vent connector.

NOTE: Should switch remain open longer than 3 minutes, furnace control board will lockout the furnace for 3 hours. To reset furnace control board, turn thermostat below room temperature or from HEAT to OFF and turn 115-V power OFF, then back ON.

3. Check Pressure Switch

This control proves operation of the draft inducer blower.

 - a. Turn off 115-V power to furnace.
 - b. Disconnect inducer motor lead wires from wire harness.
 - c. Turn on 115-V power to furnace.
 - d. Set thermostat to "call for heat" and wait 1 minute. When pressure switch is functioning properly, hot surface igniter should NOT glow and control diagnostic light flashes a status

- code (3 ! . !). If hot surface igniter glows when inducer motor is disconnected, shut down furnace immediately.
- e. Determine reason pressure switch did not function properly and correct condition.
- f. Turn off 115-V power to furnace.
- g. Reconnect inducer motor wires, replace outer door, and turn on 115-V power.
- h. Blower will run for 90 sec before beginning the call for heat again.
- i. Furnace should ignite normally.

Checklist

- Put away tools and instruments. Clean up debris.
- Check Input/Output gas pressure
- Check heat rise per application static pressure
- Cooling CFM per application static pressure
- Verify that blower-OFF delay time is selected as desired.
- Verify that blower and burner access doors are properly installed.
- Cycle test furnace with room thermostat.
- Check operation of accessories per manufacturer's instructions.
- Review User's Guide with owner.
- Attach literature packet to furnace.

SERVICE AND MAINTENANCE PROCEDURES

Untrained personnel can perform basic maintenance functions such as cleaning and replacing air filters. All other operations must be performed by trained service personnel. A qualified service person should inspect the furnace once a year.

! WARNING

FIRE, INJURY, OR DEATH HAZARD

Failure to follow this warning could result in personal injury, death and/or property damage.

The ability to properly perform maintenance on this equipment requires certain knowledge, mechanical skills, tools, and equipment. If you do not possess these, do not attempt to perform any maintenance on this equipment other than those procedures recommended in the User's Manual.

! WARNING

ELECTRICAL SHOCK, FIRE OR EXPLOSION HAZARD

Failure to follow this warning could result in personal injury or death. Before installing, modifying, or servicing system, main electrical disconnect switch must be in the OFF position and install a lockout tag. There may be more than one disconnect switch. Lock out and tag switch with a suitable warning label. Verify proper operation after servicing.

! CAUTION

ELECTRICAL OPERATION HAZARD

Failure to follow this caution may result in improper furnace operation or failure of furnace.

Label all wires prior to disconnection when servicing controls. Wiring errors can cause improper and dangerous operation.

GENERAL

These instructions are written as if the furnace is installed in an upflow application. An upflow furnace application is where the blower is located below the combustion and controls section of the furnace, and

conditioned air is discharged upward. Since this furnace can be installed in any of the 4 positions (see Fig. 3), you must revise your orientation to component location accordingly.

ELECTRICAL CONTROLS AND WIRING

The electrical ground and polarity for 115-V wiring must be properly maintained. Refer to Fig. 24 for field wiring information and to Fig. 46 for furnace wiring information.

WARNING

ELECTRICAL OPERATION HAZARD

Failure to follow this warning could result in personal injury or death. There may be more than one electrical supply to the furnace. Check accessories and cooling unit for additional electrical supplies that must be shut off during furnace servicing. Lock out and tag switch with a suitable warning label.

NOTE: If the polarity is not correct, the STATUS LED on the control will flash rapidly and Status code (F1) is displayed. This will prevent the furnace from heating. The control system also requires an earth ground for proper operation of the control and flame-sensing electrode.

The 24-V circuit contains an automotive-type, 3-amp. fuse located on the control (see Fig. 28). Any shorts of the 24-V wiring during installation, service, or maintenance will cause this fuse to blow. If fuse replacement is required, use ONLY a 3-amp. fuse. The control LED will display status code (F4) when fuse needs to be replaced.

Proper instrumentation is required to service electrical controls. The control in this furnace is equipped with a Status Code LED (Light-Emitting Diode) and Major/Minor 3 digit codes to aid in installation, servicing, and troubleshooting. Status codes can be viewed at the sight glass in blower access door. The furnace control LED is either ON continuously, rapid flashing, or a code composed of 2 digits. The major status code is displayed on the LED indicator through the door with the first digit being the number of short flashes and the second digit being the number of long flashes. The major status code is displayed in the first 2 digits of the display. The minor status code is displayed in the third digit.

For an explanation of status codes, refer to service label located on blower access door, or Fig. 45 and the troubleshooting guide by scanning the QR code or see Fig. 51 for a brief Troubleshooting Guide.

Retrieving Stored Fault Codes

The stored status code will not be erased from the control memory, if 115-V or 24-V power is interrupted. See the Service Label Fig. 45 for more information.

1. To retrieve the last 7 fault codes, proceed with the following:

NOTE: NO thermostat signal may be present at control, and all blower-OFF delays must be completed.

- a. Leave 115-V power to furnace turned on.
- b. Remove outer access door.
- c. Remove the inner blower door.
- d. Depress blower door switch to energize the control board.

CAUTION

SHOCK HAZARD

Failure to follow this caution could result in personal injury. Do not tape or permanently allow the door switch to be bypassed. Temporarily press the door switch with one hand while accessing the service buttons with your other hand. Do not touch uninsulated electrical components.

- e. Press menu/select button until (FLT) is displayed.

- f. Press Next/Option button to cycle through the fault history.

Faults remain in memory for 72 hours of powered operation after the last fault occurs. Faults may be manually cleared by selecting (CLR) with the menu/select button.

CARE AND MAINTENANCE

WARNING

FIRE OR EXPLOSION HAZARD

Failure to follow this warning could result in personal injury, death and/or property damage.

Never store anything on, near, or in contact with the furnace, such as:

1. Spray or aerosol cans, rags, brooms, dust mops, vacuum cleaners, or other cleaning tools.
2. Soap powders, bleaches, waxes or other cleaning compounds, plastic or plastic containers, gasoline, kerosene, cigarette lighter fluid, dry cleaning fluids, or other volatile fluids.
3. Paint thinners and other painting compounds, paper bags, or other paper products.

For continuing high performance and to minimize possible equipment failure, periodic maintenance must be performed on this equipment. Consult your local dealer about proper frequency of maintenance and the availability of a maintenance contract.

WARNING

ELECTRICAL SHOCK AND FIRE HAZARD

Failure to follow this warning could result in personal injury, death or property damage.

Turn off the gas and electrical supplies to the unit and install lockout tag before performing any maintenance or service. Follow the operating instructions on the label attached to the furnace.

WARNING

CARBON MONOXIDE POISONING AND FIRE HAZARD

Failure to follow this warning could result in personal injury, death and/or property damage.

Never operate unit without a filter or with filter access door removed.

CAUTION

CUT HAZARD

Failure to follow this caution may result in personal injury. Sheet metal parts may have sharp edges or burrs. Use care and wear appropriate protective clothing, safety glasses and gloves when handling parts and servicing furnaces.

The minimum maintenance on this furnace is as follows:

1. Check and clean/replace air filter each month or more frequently if required. Replace if torn.
2. Check blower motor and wheel for cleanliness each heating and cooling season. Clean as necessary.
3. Check electrical connections for tightness and controls for proper operation each heating season. Service as necessary.
4. Inspect burner compartment before each heating season for rust, corrosion, soot or excessive dust. If necessary, have furnace and burner serviced by a qualified service agency.

5. Inspect the vent pipe/vent system before each heating season for rust, corrosion, water leakage, sagging pipes or broken fittings. Have vent pipes/vent system serviced by a qualified service agency.
6. Inspect any accessories attached to the furnace such as a humidifier or electronic air cleaner. Perform any service or maintenance to the accessories as recommended in the accessory instructions.

Cleaning and/or Replacing Air Filter

The air filter arrangement will vary depending on the application. The filter is exterior to the furnace casing.

NOTE: If the filter has an airflow direction arrow, the arrow must point towards the blower.

To clean or replace filters, proceed as follows:

! WARNING

ELECTRICAL SHOCK, FIRE OR EXPLOSION HAZARD

Failure to follow this warning could result in personal injury or death, or property damage.

Before installing, modifying, or servicing system, main electrical disconnect switch must be in the OFF position and install a lockout tag. There may be more than one disconnect switch. Lock out and tag switch with a suitable warning label. Verify proper operation after servicing. Always reinstall access doors after completing service and maintenance.

1. Turn off electrical supply to furnace before removing filter access door.
2. Remove filter cabinet door.
3. Slide filter out of cabinet.
4. If equipped with permanent, washable 3/4-in. (19 mm) filter, clean filter by spraying cold tap water through filter in opposite direction of airflow. Rinse filter and let dry. Oiling or coating of the filter is not recommended. See Table 18 for size information.
5. If equipped with factory-specified disposable media filter, replace only with media filter having the same part number and size. For expandable replacement media, refer to the instructions included with the replacement media.
6. Slide filter into cabinet.
7. Replace filter cabinet door.
8. Turn on electrical supply to furnace.

Table 18 – Filter Size Information (In. / mm)

| FURNACE CASING WIDTH In. (mm) | FILTER SIZE (In. / mm) | | FILTER TYPE* |
|-------------------------------|--------------------------------|--------------------------------|--------------|
| | Side Return | Bottom Return | |
| 14-1/2 (368) | 16 x 25 x 3/4 (406 x 635 x 19) | 14 x 25 x 3/4 (356 x 635 x 19) | Washable |
| 17-1/2 (445) | 16 X 25 X 3/4 (406 x 635 x 19) | 16 X 25 X 3/4 (406 x 635 x 19) | Washable |
| 21 (533) | 16 x 25 x 3/4 (406 x 635 x 19) | 20 X 25 X 3/4 (508 x 635 x 19) | Washable |
| 24 (610) | 16 x 25 x 3/4 (406 x 635 x 19) | 24 X 25 X 3/4 (610 x 635 x 19) | Washable |

*. Recommended

Blower Motor and Wheel Maintenance

! WARNING

ELECTRICAL SHOCK HAZARD

Failure to follow this warning could result in personal injury or death. Blower access door switch opens 115-V power to control. No component operation can occur unless switch is closed. Caution must be taken when manually closing this switch for service purposes.

NOTE: The blower wheel should not be dropped or bent as balance will be affected. The following steps should be performed by a qualified service agency.

To ensure long life and high efficiency, clean accumulated dirt and grease from blower wheel and motor annually.

The inducer and blower motors are pre-lubricated and require no additional lubrication. These motors can be identified by the absence of oil ports on each end of the motor. The following steps should be performed by a qualified service agency.

Clean blower motor and wheel as follows:

1. Turn off electrical supply to furnace.
2. Remove outer door.
3. For downflow or horizontal furnaces having vent pipes within the furnace that pass in front of the blower access door:
 - a. Disconnect vent connector from furnace vent elbow.
 - b. Disconnect and remove short piece of vent pipe from within furnace.
4. Remove two screws from blower access door and remove blower access door.
5. All factory wires can be left connected, but field thermostat connections may need to be disconnected depending on their length and routing.

NOTE: The blower wheel should not be dropped or bent as balance will be affected.

6. Remove two screws holding blower assembly to blower deck and slide blower assembly out of furnace.
7. Clean blower wheel and motor using a vacuum with soft brush attachment. Blower wheel blades may be cleaned with a small paint or flux brush. Do not remove or disturb balance weights (clips) on blower wheel blades.
8. Vacuum any loose dust from blower housing, wheel and motor.
9. If a greasy residue is present on blower wheel, remove wheel from the blower housing and wash it with an appropriate degreaser.

NOTE: Before disassembly, mark blower motor, and blower housing so motor and each arm is positioned at the same location during reassembly.

To remove wheel:

- a. Disconnect power choke wires (if used) and ground wire attached to blower housing.
- b. Remove screws securing cutoff plate and remove cutoff plate from housing.
- c. Loosen set screw holding blower wheel on motor shaft (160+/-20 in.-lb. when reassembling).
- d. Remove bolts holding motor to blower housing and slide motor out of wheel (40+/-10 in.-lb. when reassembling).
- e. Remove blower wheel from housing.
- f. Clean wheel and housing.

10. Reassemble motor and blower by reversing steps 9f through 11a, finishing with 9a. Be sure to reattach ground wire to the blower housing.

11. Verify that blower wheel is centered in blower housing and set screw contacts the flat portion of the motor shaft. Loosen set screw on blower wheel and reposition if necessary.
12. Spin the blower wheel by hand to verify that the wheel does not rub on the housing.
13. Reinstall blower assembly in furnace.
14. Reinstall two screws securing blower assembly to blower deck.
15. Refer to furnace wiring diagram, and connect thermostat leads if previously disconnected.
16. To check blower for proper rotation:
 - a. Turn on electrical supply.

5. Disconnect wires to the following components. Mark wires to aid in reconnection of (be careful when disconnecting wires from switches because damage may occur):
 - a. Draft safeguard switch.
 - b. Inducer motor.
 - c. Pressure switch(es).
 - d. Limit over-temperature switch.
 - e. Gas valve.
 - f. Hot surface igniter.
 - g. Flame-sensing electrode.
 - h. Flame rollout switches.
6. Remove screws that fasten the collector box assembly to the cell panel. Be careful not to damage the collector box. Inducer assembly and elbow need not be removed from collector box.
7. Disconnect gas line from gas manifold.
8. Remove the 5 screws that attach the burner assembly to the cell panel. The gas valve and individual burners need not be removed from support assembly. Remove NOx baffles if installed.

NOTE: Be very careful when removing burner assembly to avoid breaking igniter. See Fig. 48 and Fig. 49 for correct igniter location.

WARNING

ELECTRICAL SHOCK HAZARD

Failure to follow this warning could result in personal injury, or death. Blower access door switch opens 115-V power to furnace control. No component operation can occur unless switch is closed. Exercise caution to avoid electrical shock from exposed electrical components when manually closing this switch for service purposes.

b. Manually close blower access door switch.

NOTE: If thermostat terminals are jumpered at the time blower access door switch is closed, blower will run for 90 sec before beginning a heating or cooling cycle.

- c. Perform component self-test as shown on page 31 or at the bottom of the SERVICE label (Fig. 45) which also located on the front of blower access door.
- d. Verify blower is rotating in the correct direction.
17. If furnace is operating properly, **RELEASE BLOWER ACCESS DOOR SWITCH**. Remove any jumpers or reconnect any disconnected thermostat leads. Replace blower access door.
18. Downflow or horizontal furnaces with vent pipe through furnace only:
 - a. Install and connect short piece of vent pipe inside furnace to existing vent.
 - b. Connect vent connector to vent elbow.
19. Reinstall outer door.
20. Cycle furnace through one complete heating and cooling cycle. Verify the furnace temperature rise as shown in "Adjustments" Section. Adjust temperature rise as shown in "Adjustments" Section. If outdoor temperature is below 70°F, (21°C) turn off circuit breaker to outdoor unit before running furnace in the cooling cycle. Turn outdoor circuit breaker on after completing cooling cycle.

Cleaning Heat Exchanger

The following steps should be performed by a qualified service agency:

NOTE: If the heat exchangers get a heavy accumulation of soot and carbon, they should be replaced rather than trying to clean them thoroughly. A heavy build-up of soot and carbon indicates that a problem exists which needs to be corrected, such as improper adjustment of manifold pressure, insufficient or poor quality combustion air, incorrect size or damaged manifold orifice(s), improper gas, or a restricted heat exchanger. Action must be taken to correct the problem.

If it becomes necessary to clean the heat exchangers because of dust or corrosion, proceed as follows:

1. Turn OFF gas and electrical power to furnace.
2. Remove outer access door.
3. Disconnect vent connector from furnace vent elbow.
4. For downflow or horizontal furnace having an internal vent pipe, remove internal vent pipe within the casing.

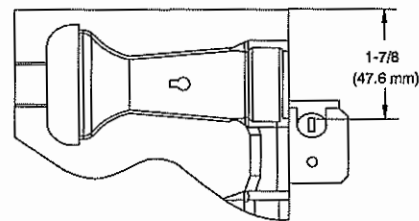

Fig. 48 – Igniter Position-Top View

A05026

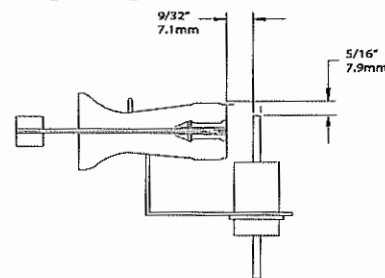

Fig. 49 – Igniter Position-Side View

A05025

NOTE: The materials needed in item 9 can usually be purchased at local hardware stores.

9. Using a field-provided 25-caliber rifle cleaning brush; a 36-in. (914 mm) long, 1/4" (6 mm) diameter steel spring cable; and a variable speed, reversible electric drill; and a vacuum cleaner, clean cells as follows:
 - a. Remove metal screw fitting from wire brush to allow insertion into cable.
 - b. Insert the twisted wire end of brush into end of spring cable, and crimp tight with crimping tool or crimp by striking with ball-peen hammer. **TIGHTNESS IS VERY IMPORTANT.**
 - (1.) Attach variable-speed, reversible drill to the end of spring cable (end opposite brush).
 - (2.) Insert brush end of cable into the outlet opening of cell and slowly rotate with drill. **DO NOT** force cable. Gradually insert cable into upper pass of cell (see Fig. 50).

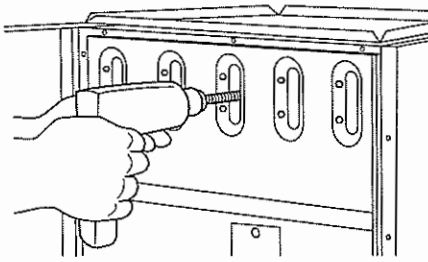

Fig. 50 – Cleaning Heat Exchanger Cell

A91252

- (3.) Work cable in and out of cell 3 or 4 times to obtain sufficient cleaning. DO NOT pull cable with great force. Reverse drill and gradually work cable out.
 - (4.) Insert brush end of cable in burner inlet opening of cell, and proceed to clean 2 lower passes of cell in same manner as upper pass.
 - (5.) Repeat foregoing procedures until each cell in furnace has been cleaned.
 - (6.) Using vacuum cleaner, remove residue from each cell.
 - (7.) Using vacuum cleaner with soft brush attachment, clean burner assembly.
 - (8.) Clean flame sensor with fine steel wool.
 - (9.) Install NOx baffles (if removed).
 - (10.) Reinstall burner assembly. Center burners in cell openings.
10. Remove old sealant from cell panel and collector box flange.
 11. Spray releasing agent on the heat exchanger cell panel where collector box assembly contacts cell panel.
 12. Apply new sealant to flange of collector box and attach to cell panel using existing screws, making sure all screws are secure.
 13. Reconnect wires to the following components. (Use connection diagram on wiring label, if wires were not marked for reconnection locations.):
 - a. Draft safeguard switch.
 - b. Inducer motor.
 - c. Pressure switch(es).
 - d. Limit over-temperature switch.
 - e. Gas valve.
 - f. Hot surface igniter.
 - g. Flame-sensing electrode.
 - h. Flame rollout switches.
 - i. Install NOx baffles (if removed).
 14. Reinstall internal vent pipe, if applicable.
 15. Reinstall vent connector on furnace vent elbow. Securely fasten vent connector to vent elbow with 2 field-supplied, corrosion-resistant, sheet metal screws located 180° apart.
 16. Replace blower access door only, if it was removed.
 17. Set thermostat above room temperature and check furnace for proper operation.
 18. Verify blower airflow and speed changes between heating and cooling.

! WARNING

FIRE OR EXPLOSION HAZARD

Failure to follow this warning could result in personal injury, death and/or property damage.

Never purge a gas line into a combustion chamber. Never test for gas leaks with an open flame. Use a commercially available soap solution made specifically for the detection of leaks to check all connections.

19. Check for gas leaks.

20. Replace outer access door.

SEQUENCE OF OPERATION

NOTE: Furnace control must be grounded for proper operation or control will lock out. Control is grounded through green/yellow wire routed to gas valve and manifold bracket screw.

Using the schematic diagram, follow the sequence of operation through the different modes. Read and follow the wiring diagram very carefully.

NOTE: If a power interruption occurs during a call for heat (W), the control will start a 90-sec blower-only ON period two seconds after power is restored, if the thermostat is still calling for gas heating. The amber LED light will flash code 12 and display will show (12 . 1) during the 90-sec period, after which the LED will be ON continuous, as long as no faults are detected. After the 90-sec period, the furnace will respond to the thermostat normally.

The blower door must be installed for power to be conducted through the blower door interlock switch ILK to the furnace control CPU, transformer TRAN, inducer motor IDM, blower motor BLWM, hot-surface igniter HSI, and gas valve GV.

1. Heating

The wall thermostat “calls for heat,” closing the R-to-W circuit. The furnace control performs a self-check, verifies the pressure switch contacts PRS are open, and starts the inducer motor IDM.

- a. **Inducer Prepurge Period** – As the inducer motor IDM comes up to speed, the pressure switch contacts PRS close, 24 VAC power is supplied for a field installed humidifier at the HUM terminal and the control begins a 15-sec prepurge period.
- b. **Igniter Warm-Up** – At the end of the prepurge period, the Hot-Surface igniter HSI is energized for a 17-second igniter warm-up period.
- c. **Trial-for-Ignition Sequence** – When the igniter warm-up period is completed, the main gas valve relay contacts GVR close to energize the gas valve GV, the gas valve opens, The gas valve GV permits gas flow to the burners where it is ignited by the HSI. Five seconds after the GVR closes, a 2-second flame proving period begins. The HSI igniter will remain energized until the flame is sensed or until the 2-second flame proving period begins.
- d. **Flame-Proving** – When the burner flame is proved at the flame-proving sensor electrode FSE, the furnace control CPU begins the blower-ON delay period and continues to hold the gas valve GV open. If the burner flame is not proved within two seconds, the control CPU will close the gas valve GV, and the control CPU will repeat the ignition sequence for up to three more Trials-For-Ignition before going to Ignition-Lockout. **Lockout will be reset** automatically after three hours or by momentarily interrupting 115 vac power to the furnace, or by interrupting 24 vac power at SEC1 or SEC2 to the furnace control CPU (not at W, G, R, etc.) If flame is proved when flame should not be present, the furnace control CPU will lock out of Gas-Heating mode and operate the inducer motor IDM until flame is no longer proved.
- e. **Blower-ON Delay** – If the burner flame is proven, the blower motor is turned on at HEAT speed 25 sec after the gas valve GV is energized. Simultaneously, the electronic air cleaner terminal EAC-1 is energized and remains energized as long as the blower motor BLWM is energized.
- f. **Heat-OFF Delay** – When the thermostat is satisfied, the R-to-W circuit is opened, de-energizing the gas valve GV, stopping gas flow to the burners, and de-energizing the 24-V humidifier terminal 24VAC HUM. The inducer motor IDM will remain ON for a 5-second post-purge period. Then turn off the inducer motor and HUM (115-V) humidifier terminal. The blower motor

BLWM and air cleaner terminal EAC 1 will remain energized for 90, 120, 150, or 180 seconds (depending on the HEAT-OFF delay selection). The furnace control CPU is factory-set for a 120-second Heat-Off Delay.

2. Cooling Mode

(See Fig. 29 for thermostat connections.) The thermostat closes the R-to-Y circuits. The R-to-Y circuit starts the outdoor unit, and the R-to-Y circuits start the furnace blower motor BLWM on COOL speed. The electronic air cleaner terminal EAC-1 is energized with 115 vac when the blower motor BLWM is operating. When the thermostat is satisfied, the R-to-Y circuits are opened. The outdoor unit will stop, and the furnace blower motor BLWM will continue operating on the COOL speed for an additional 5, 30, or 90 seconds (depending on the cooling blower-OFF delay selection). The furnace CPU is factory set for a 90 second cooling blower-OFF delay (see Fig. 28).

3. Continuous Fan Mode

When the R-to-G circuit is closed by the thermostat, the blower motor BLWM will operate at the continuous-blower speed selected. Terminal EAC-1 is energized as long as the blower motor BLWM is ON.

During a call for heat, the blower BLWM will stop during igniter warm-up (17 sec), ignition, and blower-ON delay (25 sec), allowing the furnace heat exchangers to heat up more quickly, then restarts at the end of the blower-ON delay period at HEAT speed.

When the thermostat "calls for cooling", the blower motor BLWM will continue to operate at COOL speed. When the thermostat is satisfied, the blower motor BLWM will continue to operate on COOL speed based on the cooling blower-OFF delay setting before reverting back to continuous fan speed.

When the R-to-G circuit is opened, the blower motor BLWM will continue operating for an additional 5 sec, if no other function requires blower motor BLWM operation.

4. Heat Pump

When installed with a heat pump, the furnace control automatically changes the timing sequence to avoid long blower off times during demand defrost cycles. When the R-to-W-and-Y or R-to-W-and-Y-and-G circuits are energized the furnace control CPU will continue to turn on the blower motor BLWM at HEAT speed, and begin a heating cycle. The blower motor BLWM will remain on until the end of the prepurge period, then shut off for 24 sec then come back on at HEAT speed. When the W input signal disappears, the furnace control begins a normal inducer post-purge period and the blower switches to COOL speed after a 3 sec delay. If the R-to-W-and-Y-and-G signals disappear at the same time, the blower motor BLWM will remain on for the selected blower- OFF delay period. If the R-to-W-and-Y signals disappear, leaving the G signal, the blower motor BLWM will continue running the blower motor at CONTINUOUS FAN speed after the selected heating blower-OFF delay period is completed.

Wiring Diagram

Fig. 46 shows a schematic for the furnace wiring diagram.

Troubleshooting

Refer to the service label (see Fig. 45). The Troubleshooting Guide (see Fig. 51) can be a useful tool in isolating furnace operation problems. Beginning with the word "Start," answer each question and follow the appropriate arrow to the next item. The Guide will help to identify the problem or failed component. After replacing any component, verify correct operation sequence.

TROUBLESHOOTING

Only the MAJOR flash code is seen through the sight glass on door.

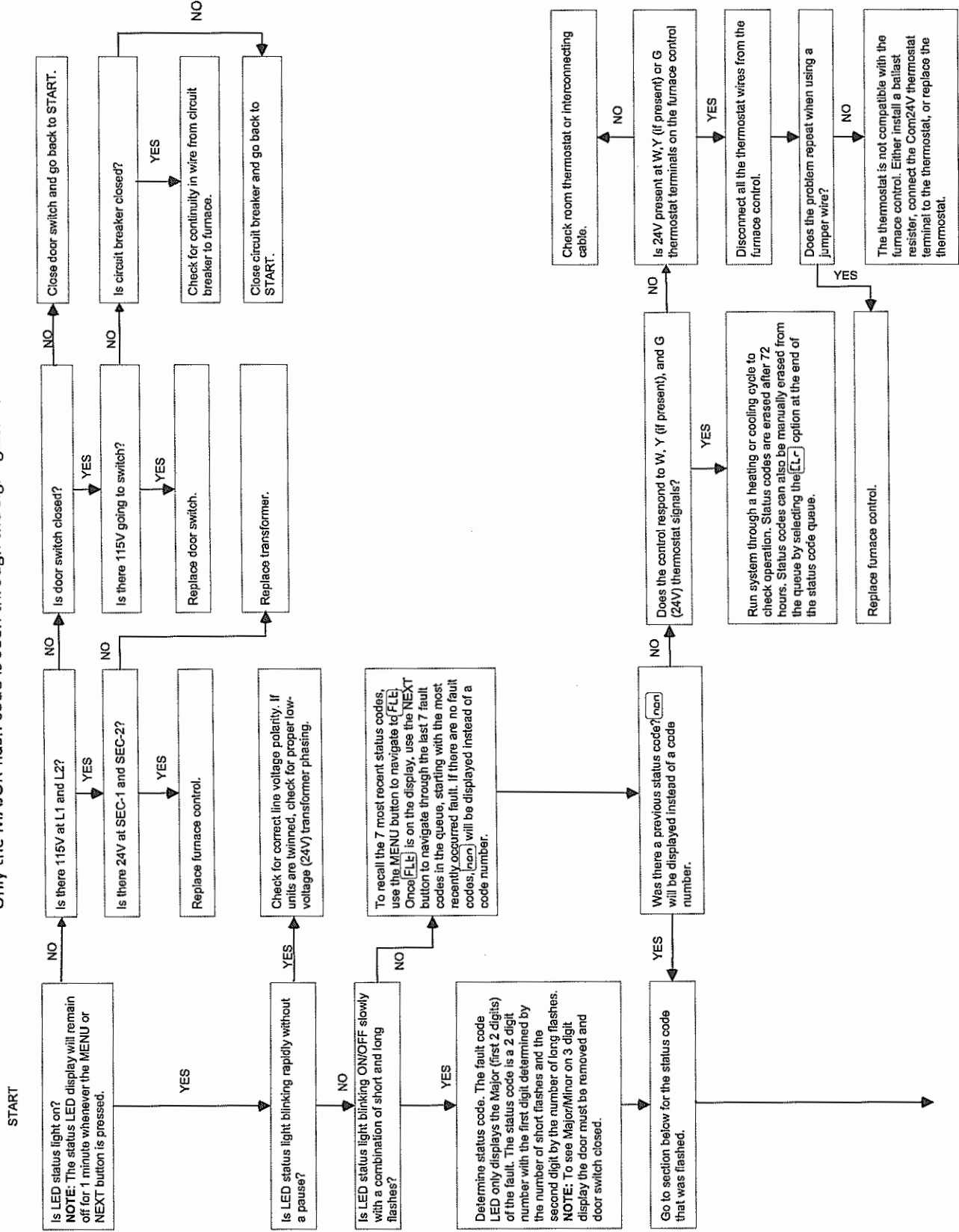

Only the MAJOR flash code is seen through the sight glass on door.

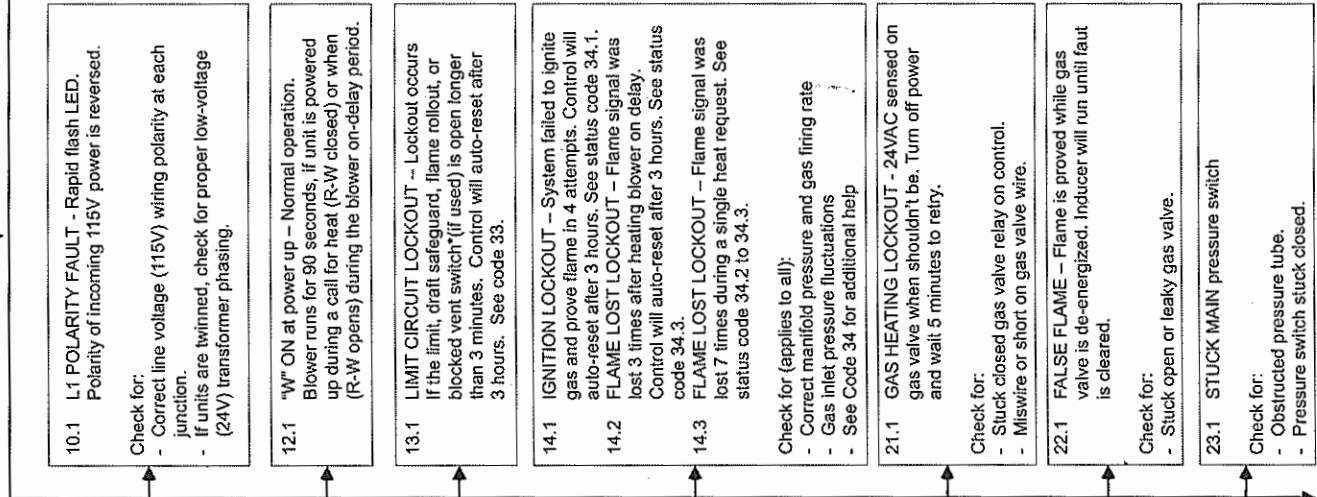

45.1 CONTROL FAILURE - flame circuit fault, memory mismatch or sequence error.
45.2 CONTROL FAILURE - gas valve relay will not close.
45.3 CONTROL FAILURE - EEPROM memory issue.
For code 45, cycle power, if code 45 repeats, replace control.

46.1 MOMENTARY LOSS of power - Heating operation will stop and will restart once the power fluctuation is resolved.

31.1 OPEN MAIN PRESSURE SWITCH - If open longer than 5 minutes, inducer shuts off for 15 minutes before retry. If opens during blower on-delay period, blower will come on for the selected blower off-delay.
Check for:
- Proper vent sizing
- Low inducer voltage (115V).
- Low inlet gas pressure (if LGPS used)
- Inadequate combustion air supply
- Disconnected or obstructed pressure tubing
- Defective inducer motor
- Defective pressure switch
- Excessive wind
- Restricted

33.1 A SWITCH HAS OPENED IN THE MAIN LIMIT - Indicates the limit, draft safeguard, flame rollout, or blocked vent shutoff switch* (if used) is open. Blower will run for 4 minutes or until open switch remakes whichever is longer. If open longer than 3 minutes, code changes to lockout #13. If open less than 3 min. status code #33 continues to flash until blower shuts off. Flame rollout switch and BVSS requires manual reset.
Check for:
- Dirty filter or restricted duct system
- Loose blower wheel
- Defective switch or connections
- Defective blower motor or capacitor
- Inadequate combustion air supply (flame rollout switch open)
- Restricted vent
- Proper vent sizing
- Excessive wind

* Blocked vent shutoff switch used in Chimney Adapter Kit

Only the MAJOR flash code is seen through the sight glass on door.

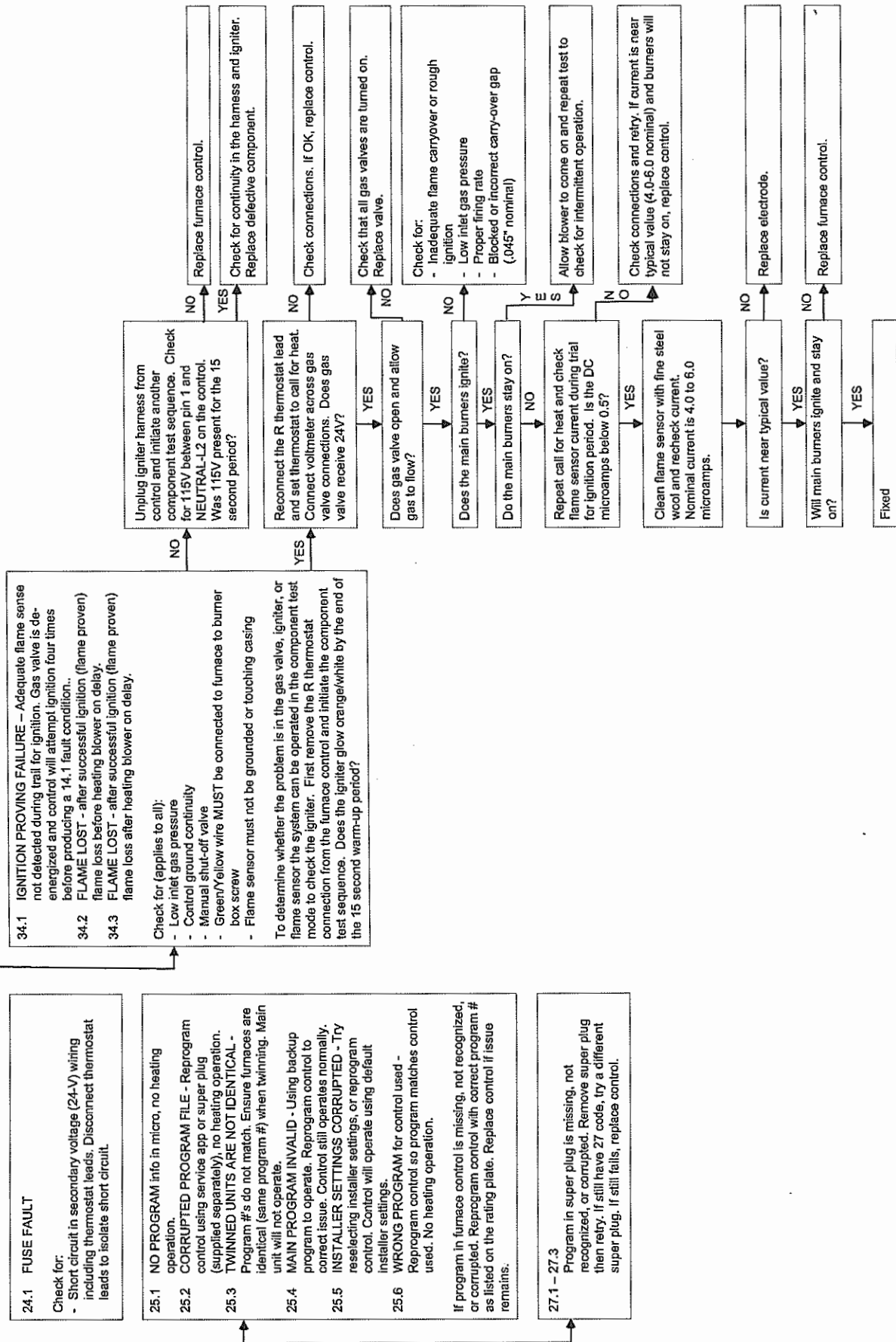

Fig. 51 – Troubleshooting Guide

GAS FURNACE CHECKLIST

Installation Date: _____

| Equipment | |
|--------------|----------|
| | Model |
| | Serial # |
| Furnace | |
| Thermostat | |
| Humidifier | |
| Indoor Coil | |
| Outdoor Unit | |

Furnace Location _____ Installed altitude _____

Furnace Orientation: ___ Upflow ___ Downflow ___ Horizontal Right ___ Horizontal Left

Gas Adjustment

LOCAL GAS HEAT CONTENT _____ (btu/cu. ft.) SPECIFIC GRAVITY _____ /cu. ft.
 (contact your local gas utility-not required for propane)

INLET SUPPLY PRESSURE** _____ in. w.c. ORIFICE # _____
 MANIFOLD PRESSURE: High fire _____ in. w.c. Low fire _____ in. w.c.

**Supply pressure should be checked with furnace and all other gas appliances running

FIRING RATE: (CLOCKED METER FOR NAT. GAS -- assure only furnace is running)

Firing rate = heat content (btu/cu. ft.) X size of the dial (cu. ft/rev) X # of rev. per 60 sec (rev/sec) X 3600 (sec/hr)

Example- (1050 btu/cu. ft.) X (0.5 cu. f. /rev.) X (2 revs./60sec) X (3600 sec/hr)= 63,000 btu/hr

OR use the "Gas Rate" chart in the startup and adjustment section of the installation manual

HIGH HEAT _____ btu/hr LOW HEAT _____ btu/hr

LEAVING AIR TEMPERATURE _____ (F) high _____ (F) low

RETURN AIR TEMPERATURE _____ (F) high _____ (F) low

TEMPERATURE RISE _____ (F) high _____ (F) low

Temperature rise is equal to the supply air temp minus the return air temp @ steady state operation.

The supply temperature should be measured away from the line of sight of the Heat Exchanger

+90 % VENTING SYSTEM

Pipe Dia _____ # of Elbows _____ Total Length _____ ft.

Termination Type: (circle one) Concentric 2 pipe (std)

Termination Locat on: (circle one) Roof Sidewall

MID-EFFICIENCY VENTING SYSTEM

METAL: (circle one) B vent Chimney Liner

Vent Dia _____ Total Ht. _____ ft. Vent Conn. Dia _____ Conn. Length _____ ft. # of Elbows _____

Connector Type: Single Wall B Vent Connector Rise Above Furnace _____ ft.

Fig. 52 – Gas Furnace Checklist

A220915

PARTS REPLACEMENT INFORMATION GUIDE

Casing Group

Outer door and Blower door
 Top filler plate
 Bottom filler plate
 Bottom enclosure

Electrical Group

Control bracket
 Junction box
 Limit switch(es)
 Circuit board
 Super plug
 Door switch
 Transformer
 Wiring harness 115-V
 Wiring harness 24-V

Blower Group

Blower cutoff
 Blower motor and Blower housing
 Blower wheel
 Grommet and Power choke (where used)

Gas Control Group

Manifold
 Orifice
 Flame sensor
 Hot surface igniter
 Gas valve
 Manual reset limit switches
 Burner assembly and Burner support assembly

Heat Exchanger Group

Heat exchanger cell
 Cell panel
 Low NOx baffle (California models only)

Inducer Group

Inducer motor and Inducer wheel
 Pressure switch
 Housing assembly
 Vent elbow assembly
 Draft safeguard switch

TO OBTAIN INFORMATION ON PARTS: Consult your installing dealer or a licensed Heating and Air Conditioning company of your choice:

CAC/BDP
 a division of Carrier Corporation
 7310 West Morris Street
 Indianapolis, IN 46231 U.S.A.

Have available the model number, series number, and serial number located on the unit rating plate to ensure correct replacement part.

MODEL NOMENCLATURE

| MODEL | COOLING CAPACITY | HEATING CAPACITY | WIDTH | SERIES | VARIATIONS |
|----------|------------------|------------------|-------|--------|------------|
| PG80MSAA | 36 | 070 | A | A | A |

WARNING

FIRE, EXPLOSION, ELECTRICAL SHOCK AND CARBON MONOXIDE POISONING HAZARD

Failure to follow this warning could result in dangerous operation, personal injury, death or property damage.

Improper installation, adjustment, alteration, service, or maintenance can cause personal injury, property damage, or death. Consult a qualified installer, service agency, or your local gas supplier for information or assistance. The qualified installer or service agency must use only factory-authorized replacement parts, kits, or accessories when modifying this product.

WARRANTY CONDITIONS:

1. To obtain a ten-year warranty the product must be properly registered at www.cac-bdp-all.com within ninety (90) days of original installation. In jurisdictions where warranty benefits conditioned on registration are prohibited by law, registration is not required and the warranty period will be 10 years.
2. Where a product is installed in a newly constructed home, the date of installation is the date the homeowner purchased the home from the builder.
3. If the date of original installation cannot be verified, then the warranty period begins ninety (90) days from the date of product manufacture (as indicated by the model and serial number). Proof of purchase may be required at time of service.
4. Product must be installed properly and by a licensed HVAC technician.
5. The warranty applies only to products remaining in their original installation location.
6. Installation, use, care, and maintenance must be normal and in accordance with instructions contained in the Installation Instructions, Owner's Manual and Company's service information.
7. Defective parts must be returned to the distributor through a registered servicing dealer for credit.

LIMITATIONS OF WARRANTIES: ALL IMPLIED WARRANTIES AND/OR CONDITIONS (INCLUDING IMPLIED WARRANTIES OR CONDITIONS OF MERCHANTABILITY AND FITNESS FOR A PARTICULAR USE OR PURPOSE) ARE LIMITED TO THE DURATION OF THIS LIMITED WARRANTY. SOME STATES OR PROVINCES DO NOT ALLOW LIMITATIONS ON HOW LONG AN IMPLIED WARRANTY OR CONDITION LASTS, SO THE ABOVE MAY NOT APPLY TO YOU. THE EXPRESS WARRANTIES MADE IN THIS WARRANTY ARE EXCLUSIVE AND MAY NOT BE ALTERED, ENLARGED, OR CHANGED BY ANY DISTRIBUTOR, DEALER, OR OTHER PERSON WHATSOEVER.

THIS WARRANTY DOES NOT COVER:

1. Labor or other costs incurred for diagnosing, repairing, removing, installing, shipping, servicing or handling of either defective parts, or replacement parts, or new units.
2. Any product not installed pursuant to applicable regional efficiency standards issued by the Department of Energy.
3. Any product purchased over the Internet.
4. Normal maintenance as outlined in the installation and servicing instructions or Owner's Manual, including filter cleaning and/or replacement and lubrication.
5. Failure, damage or repairs due to faulty installation, misapplication, abuse, improper servicing, unauthorized alteration or improper operation.
6. Failure to start or damages due to voltage conditions, blown fuses, open circuit breakers, or the inadequacy, unavailability, or interruption of electrical, Internet service provider, or mobile device carrier service or your home network.
7. Failure or damage due to floods, winds, fires, lightning, accidents, corrosive environments (rust, etc) or other conditions beyond the control of Company.
8. Parts not supplied or designated by Company, or damages resulting from their use.
9. Products installed outside the U.S.A. or Canada.
10. Electricity or fuel costs, or increases in electricity or fuel costs from any reason whatsoever, including additional or unusual use of supplemental electric heat.
11. Any cost to replace, refill or dispose of refrigerant, including the cost of refrigerant.
12. **ANY SPECIAL, INDIRECT OR CONSEQUENTIAL PROPERTY OR COMMERCIAL DAMAGE OF ANY NATURE WHATSOEVER.**
Some states or provinces do not allow the exclusion of incidental or consequential damages, so the above limitation may not apply to you.

This Warranty gives you specific legal rights, and you may also have other rights which vary from state to state or province to province.



Limited Warranty for Non-Condensing Gas Furnace

FOR WARRANTY SERVICE OR REPAIR:

Contact the installer. You may find their name on the product or in your Owner's Packet.

For additional help, contact: CAC\BDP, Consumer Relations, Phone 1-888-695-1488.

PRODUCT REGISTRATION: Register your product online at www.cac-bdp-all.com Retain this document for your records.

Model No. _____

Unit Serial No. _____

Date of Installation _____

Installed by _____

Name of Owner _____

Address of Installation _____

CAC\BDP (hereinafter "Company") warrants this product against failure due to defect in material or workmanship under normal use and maintenance as follows. Warranty periods begin on the date of original installation. If a part fails due to defect within the warranty period, Company will either provide only a new or remanufactured part to replace the failed defective part without charge for the part. Alternatively, and at its option, the Company will provide a credit in the amount of the then factory selling price for a new equivalent part toward the retail purchase price of a new Company product. Except as otherwise stated herein, those are Company's exclusive obligations under this warranty for a product failure. This limited warranty is subject to all provisions, conditions, limitations and exclusions listed below and on the reverse (if any) of this document.

RESIDENTIAL APPLICATIONS

This warranty is to the original purchasing owner and subsequent owners only to the extent as stated in the Warranty Conditions and below. Except as otherwise stated, **if the product is properly registered within 90 days after original installation (see Warranty Conditions below for registration instructions), then the warranty period will be ten (10) years from the date of installation. Otherwise the warranty period is five (5) years from the date of installation.** Additionally, the warranty period on the heat exchanger is twenty (20) years.

| Product | Item | Limited Warranty (Years) | |
|----------------------------|----------------|--------------------------|-------------------|
| | | Original Owner | Subsequent Owners |
| Non-Condensing Gas Furnace | Parts | 10* (or 5) | 5 |
| | Heat Exchanger | 20 | 20 |

OTHER APPLICATIONS

The warranty period is twenty (20) years on the heat exchanger and one (1) year on all other parts. The warranty is to the original owner only and is not available to subsequent owners

LEGAL REMEDIES: The owner must notify the Company in writing, by certified or registered letter to CAC\BDP, Warranty Claims, P.O. Box 4808, Syracuse, New York 13221, of any defect or complaint with the product, stating the defect or complaint and a specific request for repair, replacement, or other correction of the product under warranty, mailed at least thirty (30) days before pursuing any legal rights or remedies.



NOTE TO EQUIPMENT OWNER:

For your convenience, please record the model and serial numbers of your new equipment in the spaces provided. This information, along with the installation data and dealer contact information will be helpful should your system require maintenance or service.

FURNACE

Model # _____

Serial # _____

AIR CONDITIONER OR HEAT PUMP

Model # _____

Serial # _____

INDOOR COIL (Furnace Coil or Fan Coil)

Model # _____

Serial # _____

INSTALLATION INFORMATION:

Date Installed _____

DEALERSHIP CONTACT INFORMATION:

Company Name _____

Address _____

Phone Number _____

Technician Name _____

NOTE TO INSTALLER:

This manual must be left with the equipment owner.

A200102

MAINTENANCE CHECKLIST

In addition to the type of routine maintenance you might be willing to perform; your furnace should be inspected regularly by a properly trained service technician.

You should work with your dealer or service technician to assure your inspection includes the following at a minimum.

This list may not include all maintenance items, and inspection interval times may vary depending on operational conditions of the furnace.

| DESCRIPTION | INSPECTION INTERVAL | | |
|--|---------------------|---------------|----------|
| | Monthly | Semi-Annually | Annually |
| Furnace specific, external items: | | | |
| Clean or replace air filters. | X | | |
| Inspect cabinet for signs of damage. | X | | |
| Inspect and clean door louvers if needed. | | X | |
| Inspect electrical disconnect for proper function. Repair or replace as necessary. | | X | |
| Inspect external wiring for damage. | | X | |
| Inspect gas supply line and manual shut-off for leaks. | | | X |
| Ensure there is no debris or clutter that could interfere with operation of furnace | X | | |
| Furnace specific, internal items: | | | |
| Inspect and clean blower assembly (includes blower housing, blower wheel and motor). | | X | |
| Inspect gas valve and check for proper manifold gas pressure Adjust as needed. | | | X |
| Inspect ignition system and safety controls. Clean and adjust as needed. | | | X |
| Inspect control box, associated controls, wiring and connections. | | | X |
| Check combustion blower housing for lint and debris and clean as necessary. | | | X |
| Inspect burner assembly - clean as needed. | | | X |
| Inspect heat exchanger - clean as needed. | | | X |
| Inspect flue system-check for proper attachment to the furnace, any dislocated sections, and for signs of corrosion. Replace if necessary. | | | X |
| Clean out condensate trap and refill with water | | | X |
| Measure combustion byproducts with calibrated analyzer to ensure byproducts are within acceptable range | | | X |
| System: | | | |
| Inspect airflow system (ductwork)-check for leaks and repair as needed. | | X | |
| Inspect evaporator coil, drain pan and condensate drain lines as applicable. Clean as needed. | | X | |

COMBUSTION AREA AND VENT SYSTEM**! WARNING****ELECTRICAL OPERATION HAZARD**

Failure to follow this warning could result in personal injury or death. For proper and safe operation the furnace needs air for combustion and ventilation. Do not block or obstruct air openings on the furnace, air opening to the area in which the furnace is installed, and the space around the furnace.

! WARNING**UNIT OPERATION HAZARD**

Failure to follow this caution may result in personal injury. Failure to follow this warning could result in personal injury or death. For proper and safe operation the furnace needs air for combustion and ventilation. Do not block or obstruct air openings on the furnace, air opening to the area in which the furnace is installed, and the space around the furnace.

Inspect the combustion area and vent system before each heating season. An accumulation of dirt, soot, or rust can mean a loss of efficiency and improper performance. Buildups on the main burners can cause faulty firing. This "delayed ignition" is characterized by an alarmingly loud sound.

NOTE: If your furnace makes a loud noise when the main burners are ignited, shut down the furnace and call your servicing dealer. Use your flashlight and follow these steps for inspecting the combustion area and vent system of your furnace:

1. Turn off electrical supply to the furnace and remove the access door (see Fig. 6 and Fig. 7).
2. Carefully inspect the gas burner for dirt, rust, or scale. Inspect the elbow, flue connection area, and the vent pipe for rust.

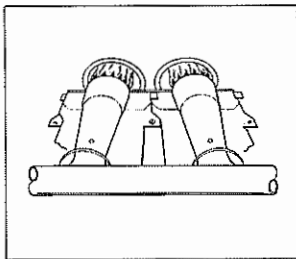

Fig. 20 – Burner Flame

A92330

! WARNING**CARBON MONOXIDE POISONING HAZARD**

Failure to follow this warning could result in personal injury or death. If dirt, rust, soot, or scale accumulations are found, call your dealer. Do not operate your furnace.

3. Inspect the vent pipe for a sag, holes, or a disconnection. A horizontal vent pipe must slope upward away from furnace. If rusty joints or seams, or signs of water leakages are found, call your dealer for service.

! WARNING**CARBON MONOXIDE POISONING HAZARD**

Failure to follow this warning could result in personal injury or death. If holes are found or if the vent pipe is obstructed or is not connected, toxic fumes can escape into your home. **DO NOT OPERATE YOUR FURNACE.** Call your dealer for service.

4. Restore electrical power to the furnace (see Fig. 11).
5. Start the furnace and observe its operation. If possible, watch the burner flames. Are they burning bright blue? If not or if you suspect some other malfunction, call your servicing dealer.
6. Replace the access door (see Fig. 10).

BEFORE YOU REQUEST A "SERVICE CALL"

Before you call for service, check for several easily solved problems:

- Check for sufficient airflow. Check the air filter for dirt. Check for blocked return-air or supply-air grilles. Be sure they are open and unobstructed. If this isn't the cause of the problem, call your servicing dealer. If your furnace isn't operating at all, check the following list for easily solved problems:
- Is your thermostat set above room temperature? Is the HEAT mode selected?
- Is the electrical power supply switch on? Is the blower access door firmly in place? Are any fuses blown? (There is a fuse on the furnace control.) Has a circuit breaker tripped?
- Is the manual shut-off valve in the gas supply pipe leading to the furnace open? Does the lever point in the same direction that the pipe runs (open)? Or is it at a right angle to the pipe (closed)?

NOTE: Before proceeding with the next checks, turn off the electrical power supply to the furnace. Remove access door.

- Is the switch on the gas valve turned to the ON position? If this or the preceding check shows an interruption in the gas supply, make sure the gas has not been shut off for safety reasons. If nothing else seems to be wrong, follow the start-up procedures found on pages 3 and 4 of this booklet.

! CAUTION**UNIT OPERATION HAZARD**

Failure to follow this caution may result in personal injury. If for some reason the vent is blocked, the draft safeguard switch will shut off the furnace. (See Page 2 for switch location.) The switch will automatically reset after the furnace cools off. If the furnace fails to operate, contact a qualified service agency.

- Check the manual reset limit switches located on the ends of the burner enclosure (see Fig. 1 and Fig. 2). If the furnace has experienced a high-temperature condition due to inadequate combustion air, these switches will shut off the furnace. Reset the switches by pushing the button on the switch. If the switch trips a second time, turn off the furnace and call for service.
- If your furnace still fails to operate, call your servicing dealer for troubleshooting and repairs. Tell your dealer the model and serial numbers for your furnace. (You should have them recorded on page 7 of this booklet.) By knowing exactly which furnace you have, the dealer may be able to offer suggestions over the phone or save valuable time through knowledgeable preparation for the service call.

In addition to the type of routine maintenance you might be willing to perform, your furnace should be inspected regularly by a properly trained service technician. You should work with your dealer or service technician to assure your inspection includes the following at a minimum.

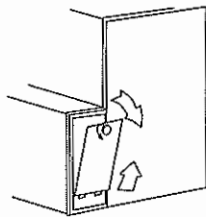

Representative drawing only, some model may vary.

Fig. 14 – Removing Side Filter Cabinet Door

A06190

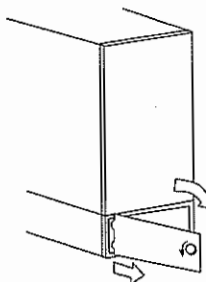

Representative drawing only, some model may vary.

Fig. 15 – Removing Bottom Filter Cabinet Door

A06191

5. Slide air filter out of filter cabinet. Keep dirty side up (if dirty) to avoid spilling dirt (see Fig. 16 and Fig. 17).

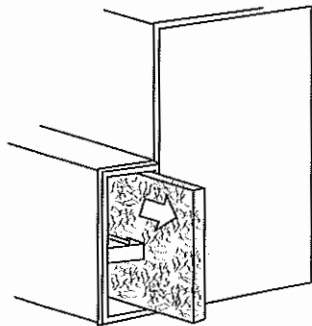

Representative drawing only, some model may vary.

Fig. 16 – Slide Side Filter Out of Furnace

A00227

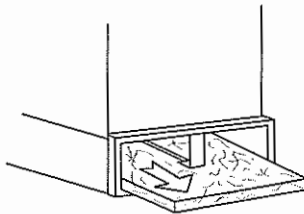

Representative drawing only, some model may vary.

Fig. 17 – Slide Bottom Filter Out of Furnace

A00228

6. Inspect the filter. If torn, replace it.

NOTE: If a washable filter has been replaced with:

- a. Factory specified disposable media filter — Do not clean. If dirty, replace only with media filter having the same part number and size. Install with airflow direction arrow pointing towards blower (some models may vary).
- b. Electronic Air Cleaner (EAC) — Refer to EAC Owner's Manual for maintenance information (some models may vary).
- c. Factory specified disposable filter, do not clean. Replace it with a new filter of same size.
- d. Wash filter (if dirty) in sink, bathtub, or outside with a garden hose. Always use cold tap water. A mild liquid detergent may be used if necessary. Spray water through filter in the opposite direction of airflow. Allow filter to dry.

7. Reinstall clean air filter.

8. Replace filter cabinet door (see Fig. 18 and Fig. 19).
9. Turn on electrical supply to furnace (see Fig. 11).

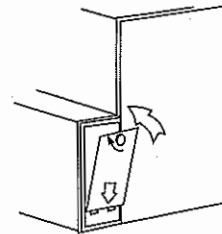

Representative drawing only, some model may vary.

Fig. 18 – Replace Side Filter Cabinet Door

A06192

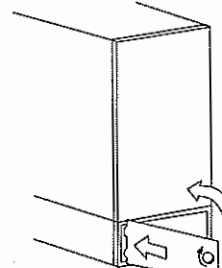

Representative drawing only, some model may vary.

Fig. 19 – Replace Bottom Filter Cabinet Door

A06193

NOTE: If side return ducts are used, two filters may be required in some models. The procedure listed above may be used to remove side filters. Filters may be field modified by cutting filter material and support rods (3) in filters. Alternate sizes and additional filters may be ordered from your dealer.

! CAUTION

PERSONAL INJURY HAZARD

Failure to follow this caution may result in personal injury.

Use care when cutting support rods in filters to protect against flying pieces and sharp rod ends. Wear safety glasses, gloves, and appropriate protective clothing.

| FURNACE | FILTER QUANTITY AND SIZE* | | FILTER TYPE† |
|--------------|----------------------------|----------------------------|--------------|
| | SIDE RETURN IN(MM) | BOTTOM RETURN IN(MM) | |
| 14-1/2 (368) | (1) 16 x 25 (406 x 635) | (1) 14 x 25 (356 x 635) | Washable |
| 17-1/2 (445) | (1) 16 x 25 (406 x 635) | (1) 16 x 25 (406 x 635) | Washable |
| 21 (533) | (1) 16 x 25 (406 x 635) | (1) 20 x 25 (508 x 635) | Washable |
| 24 (610) | (1) 16 x 25 (406 x 635) | (1) 24 x 25 (610 x 635) | Washable |

*. Some furnaces may have 2 filters

†. Recommended

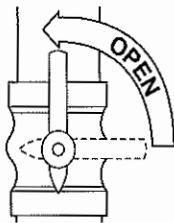

Fig. 12 – Open Valve

A06189

11. Set the room thermostat to a temperature slightly above the room temperature. This will automatically signal the furnace to start. The inducer motor will start and the hot surface igniter will energize. When hot, the igniter will have an orange glow.
12. After about 17 seconds, the gas valve permits gas to flow to the main burners where it is ignited. Hot flames begin to warm the furnace's heat exchanger. After a time delay of approximately 25-45 seconds the furnace blower is switched on.

NOTE: If the main burners fail to ignite, the furnace control system will go through three more ignition cycles. Then if burners fail to ignite, the system will lockout. If lockout occurs or the blower does not come on, shut down your furnace and call your dealer for service.

13. Set your thermostat to the temperature that satisfies your comfort requirements.

SUGGESTION: Setting the thermostat back a few degrees—and compensating for the difference with warmer clothing—can make a big difference in your fuel consumption on extremely cold days. The few degrees at the top of your thermostat “comfort level” are the most costly degrees to obtain.

When the room temperature drops below the temperature selected on the thermostat, the furnace will switch on automatically. When the room temperature reaches the setting selected on the thermostat, the furnace will be automatically switched off.

Continuous Fan Operation - Some thermostats have a “FAN” switch with 2 selections: AUTO and ON. When thermostat is set on AUTO, the furnace blower cycles on and off, controlled by the thermostat. In ON position, the furnace blower runs continuously except for a 42-62 sec delay at the “call for heat.” Continuous fan keeps the temperature level in your home more evenly balanced. It also continuously filters the indoor air.

SHUTTING DOWN YOUR FURNACE

Should you ever suspect a malfunction in your furnace, you will need to turn the furnace off. The following procedures must be followed:

1. Set your room thermostat to the lowest temperature setting (see Fig. 4).
2. Close the external manual gas valve (see Fig. 5).
3. Turn off electrical supply to the furnace (see Fig. 6).
4. Remove outer furnace door (see Fig. 7).
5. Turn the switch on the gas control to the OFF position (see Fig. 8).
6. Replace the outer furnace door (see Fig. 10).
7. If the furnace is being shut down because of a malfunction, call your dealer as soon as possible.

PERFORMING ROUTINE MAINTENANCE

With proper maintenance and care, your furnace will operate economically and dependably. Instructions for basic maintenance are found on this and the following pages. However, before beginning maintenance, follow these safety precautions:

! WARNING

ELECTRICAL SHOCK HAZARD

Failure to follow this warning could result in personal injury or death. Turn off electrical power supply to your furnace before removing the access doors to service or perform maintenance.

! CAUTION

CUT HAZARD

Failure to follow this caution may result in personal injury. Although special care has been taken to minimize sharp edges, be extremely careful when handling parts or reaching into the furnace. Wear safety glasses, gloves, and appropriate protective clothing.

FILTERING OUT TROUBLE

! CAUTION

UNIT PERFORMANCE HAZARD

Failure to follow this caution may result in product damage. Never operate your furnace without a filter in place. Doing so may damage the furnace blower motor. An accumulation of dust and lint on internal parts of your furnace can cause a loss of efficiency.

A dirty filter will cause excessive stress on the furnace, heat exchanger, and blower motor and can cause it to overheat and automatically shut down. The furnace filter should be checked every 4 weeks and cleaned or replaced if necessary.

If installed with factory specified disposable media filter, check or replace filter before each heating and cooling season. Replace disposable media filter at least twice a year.

If your furnace filter needs replacing, be sure to use the same size and type of filter that was originally specified.

The air filter for the furnace may be located in a filter cabinet/rack attached to the side or bottom of the furnace. If air filter has been installed in another location, contact your dealer for instructions. To inspect, clean and/or replace the air filter(s), follow these steps:

1. Turn off the electrical supply to the furnace (see Fig. 13).

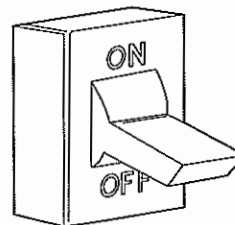

Fig. 13 – Turn Off Electrical Supply

A92185

2. Remove filter cabinet door/rack.
3. Remove filter cabinet door (see Fig. 14 and Fig. 15).
4. It may be necessary to remove 1 thumbscrew.

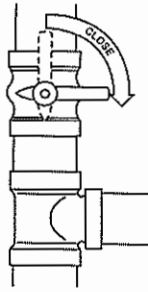

Fig. 5 – Close Valve

3. Turn OFF electrical supply to the furnace (see Fig. 6).

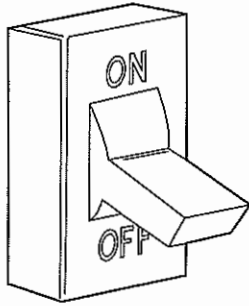
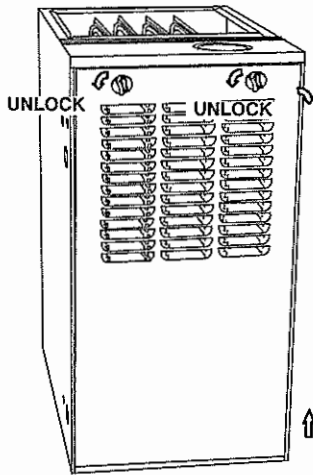

Fig. 6 – Turn Off Electrical Supply

4. Remove the outer door by loosening the thumbscrew and pulling the door forward (see Fig. 7).



A200117

Representative drawing, some models may vary in appearance.

Fig. 7 – Remove Furnace Door

5. Turn the control switch on the gas control to the OFF position and wait 5 minutes (see Fig. 8). Then smell for gas, including near the floor. If you smell gas, STOP! Follow "B" on furnace label. If you don't smell gas, go to next step.

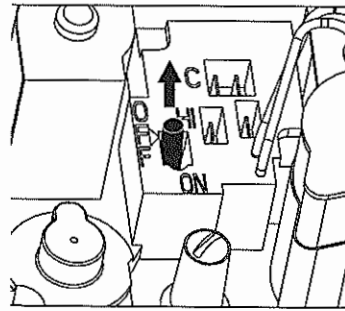

A06188

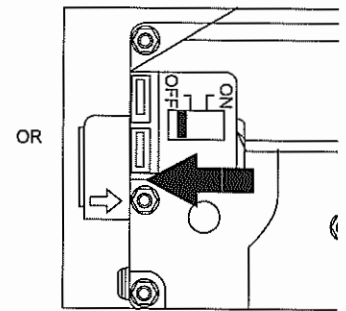

OR

A02266

Fig. 8 – Control Switch to OFF

6. After waiting 5 minutes, if you still smell gas, STOP! Follow the safety information on the cover of this manual. If you do not smell gas, go to the next step.

7. Turn the control switch to ON (see Fig. 9).

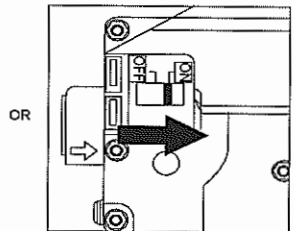
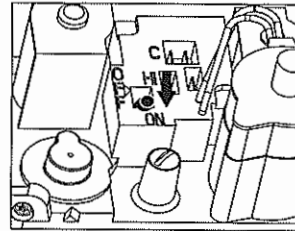

OR

A02267

Fig. 9 – Control Switch to ON

8. Replace the outer door and tighten the thumbscrew (see Fig. 10).

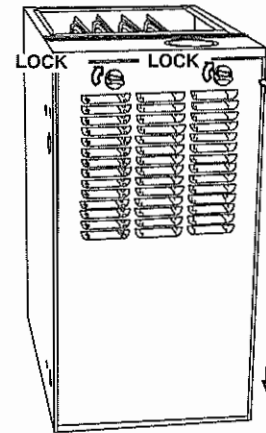

A200118

Representative drawing, some models may vary in appearance.

Fig. 10 – Furnace Door Replaced

9. Turn ON the electrical supply to the furnace (see Fig. 11).

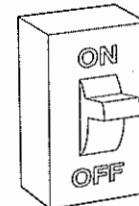

A92359

Fig. 11 – Turn On Electrical Supply

10. Open the external manual gas valve (see Fig. 12).

TABLE OF CONTENTS

IMPORTANT FACTS (DO'S AND DON'TS) 2
 FURNACE COMPONENTS 2
 TABLE OF CONTENTS 3
 SAFETY CONSIDERATIONS 3
 BEFORE STARTING YOUR FURNACE 3
 STARTING YOUR FURNACE 3
 STEPS FOR STARTING YOUR FURNACE 3
 SHUTTING DOWN YOUR FURNACE 5
 PERFORMING ROUTINE MAINTENANCE 5
 FILTERING OUT TROUBLE 5
 COMBUSTION AREA AND VENT SYSTEM 7
 BEFORE YOU REQUEST A "SERVICE CALL" 7
 MAINTENANCE CHECKLIST 8

! WARNING

FIRE OR EXPLOSION HAZARD
 Failure to follow warnings could result in personal injury, death, or property damage.
 Keep insulation clear of furnace and maintain clearances shown on unit clearance label.

SAFETY CONSIDERATIONS

Installing and servicing heating equipment can be hazardous due to gas and electrical components. Only trained and qualified personnel should install, repair, or service heating equipment.

Untrained personnel can perform basic maintenance functions such as cleaning or replacing air filters. All other operations must be performed by trained service personnel. Observe safety precautions in this manual, on tags, and on labels attached to the furnace, and other safety precautions that may apply.

Recognize safety information. This is the safety-alert symbol . When you see this symbol on the furnace and in instructions or manuals, be alert to the potential for personal injury.

Understand the signal words DANGER, WARNING, and CAUTION. These words are used with the safety-alert symbol. DANGER identifies the most serious hazards which will result in severe personal injury or death. WARNING signifies hazards which could result in personal injury or death. CAUTION is used to identify unsafe practices which would result in minor personal injury or product and property damage. NOTE is used to highlight suggestions which will result in enhanced installation, reliability or operation.

BEFORE STARTING YOUR FURNACE

Examine the furnace installation to determine that:

1. All flue gas carrying areas external to the furnace (i.e. chimney, vent connector) are clear and free of obstructions.
2. The vent connector is in place, slopes upward and is physically sound without holes or excessive corrosion.
3. The return-air duct connection(s) is physically sound, is sealed to the furnace casing, and terminates outside the space containing the furnace.
4. The physical support of the furnace is sound without sagging cracks, gaps, etc. around the base.
5. There are no obvious signs of deterioration of the furnace.

STARTING YOUR FURNACE

Your furnace uses an automatic, hot surface ignition system to light the burners each time the thermostat signals the furnace to start.

Follow these important safeguards:

- Never attempt to manually light the burners with a match or other source of flame.



Fig. 3 – Do Not Light Burner with Match

A92319

- Read and follow the operating instructions on inside of main furnace door, especially the item that reads as follows:
 "Wait 5 minutes to clear out any gas. Then smell for gas, including near the floor. If you smell gas, STOP! Follow "B" in the safety information above on this furnace label. If you don't smell gas, go to the next step."
- If a suspected malfunction occurs with your gas control system, such as the burners do not light when they should, refer to the shutdown procedures on inside of main furnace door, or in the "Shutting Down Your Furnace" section and call your dealer as soon as possible.
- Should the gas supply fail to shut off or if overheating occurs, shut off the gas valve to the furnace before shutting off the electrical supply.

! WARNING

FIRE AND EXPLOSION HAZARD
 Failure to follow this warning could result in personal injury, death or property damage.
 Should the gas supply fail to shut off or if overheating occurs, shut off the gas valve to the furnace BEFORE shutting off the electrical supply and install lockout tag.

- **CHECK AIR FILTER:** Before attempting to start your furnace, be sure the furnace filter is clean and in place (see "Performing Routine Maintenance" section in this manual. Do not run the furnace without a filter in place. Then proceed as follows:

STEPS FOR STARTING YOUR FURNACE

1. Set your room thermostat to the lowest temperature setting (see Fig. 4).

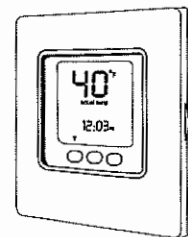

Fig. 4 – Lowest Temperature Setting

A09564

2. Close the external manual gas valve (see Fig. 5).

WELCOME TO TODAY'S GENERATION OF COMFORT

Congratulations! Your new gas furnace is a sound investment which will reward you and your family with years of warm memories winter after winter.

Not only is your new furnace energy efficient, it is also extremely reliable. Spend just a few minutes with this booklet to learn about the operation of your new furnace-and the small amount of maintenance it takes to keep it operating at peak efficiency. Years went into the development of your new furnace. Take a little time now to assure its most efficient operation for years to come.

IMPORTANT FACTS (DO'S AND DON'TS)

- DO: READ AND UNDERSTAND THIS MANUAL.
- DO: Have your furnace and vent system inspected annually by a qualified service technician.
- DO: Inspect your filter monthly and clean or replace when needed.
- DO: Provide adequate airflow to the furnace for efficient combustion and safe ventilation.
- DO: Keep your furnace free and clear of insulating material (some materials may be combustible. Examine the furnace area when the furnace is installed or when insulation is added.
- DO NOT: Enclose your furnace in an airtight room or seal it behind solid doors.
- DO NOT: Keep combustible materials, gasoline, and other flammable liquids or vapors around your furnace.
- DO NOT: Cover your furnace in any manner.
- DO NOT: Store anything (including trash or debris) near your furnace.
- DO NOT: In any way block or restrict airflow around your furnace.
- DO NOT: In any way block or restrict airflow to your supply air and return air grills.
- DO NOT: Use your furnace room as a broom closet or a place to store any kind of chemical or cleaner.
- DO NOT: Contaminate the air used for combustion of your furnace with any kind of chemical or fumes. This could also cause heat exchangers, metal vent systems or components to deteriorate.

NOTE: These chemicals or fumes are present in many products around the home, such as: water softener salts, any type of household cleaning product, any type of laundry product, adhesives, paints, varnishes, paint strippers, waxes and plastics, etc.

During remodeling be sure the combustion air is fresh and uncontaminated. If these compounds are burned in your furnace, the heat exchangers and metal vent system may deteriorate.

NOTE: The qualified installer or agency must use only factory-authorized replacement parts, kits, and accessories when modifying this product.

This furnace contains safety devices which must be manually reset. If the furnace is left unattended for an extended period of time, have it checked periodically for proper operation. This precaution will prevent problems associated with no heat, such as frozen water pipes, etc (see "Before You Request a Service Call" section in this manual.)

FURNACE COMPONENTS

Furnace shown in upflow position; may be used in downflow or horizontal orientation or applications. Vent Elbow may be turned to a different position, depending on type of installation.

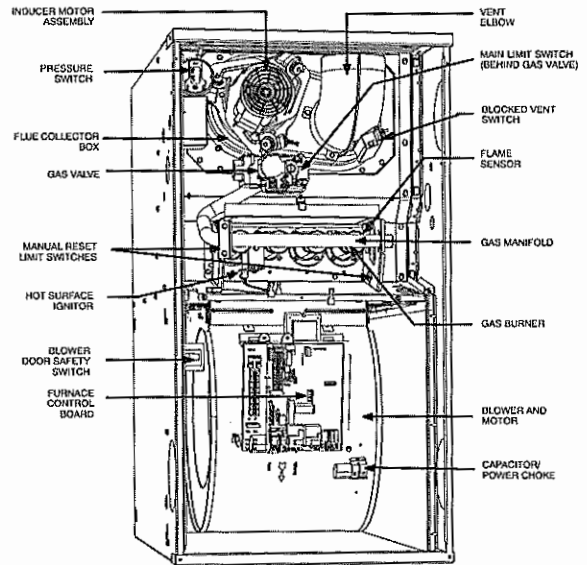

RATING PLATE NOT SHOWN
(LOCATED ON BLOWER DOOR)

Fig. 1 – 80% AFUE Single Stage Furnace Components

A10259

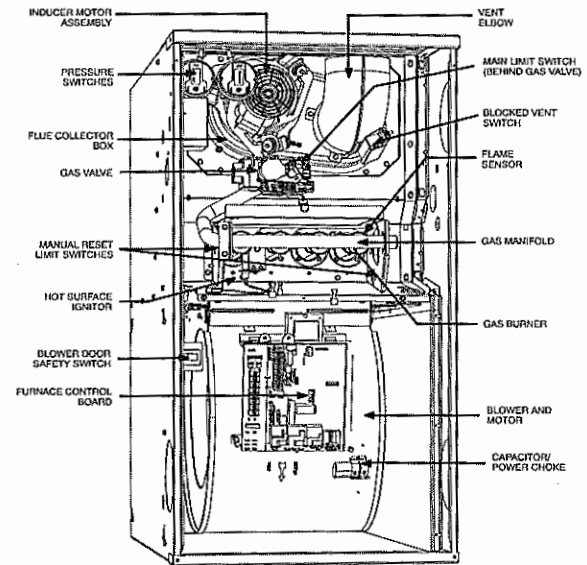

RATING PLATE NOT SHOWN
(LOCATED ON BLOWER DOOR)

Fig. 2 – 80% AFUE Two-Stage Furnace Components

A10260

! **WARNING**

FIRE OR EXPLOSION HAZARD

Failure to follow this warning could result in injury, death, or property damage.

Do not keep combustible materials, gasoline, and other flammable liquids or vapors around your furnace.

NON-CONDENSING, 80% AFUE GAS FURNACE

OWNER'S MANUAL

NOTE: Read the entire instruction manual before starting the installation.

Our products are designed, tested and built in accordance with Department of Energy (DOE) standardized procedures; however, actual operating results and efficiencies may vary based on manufacturing and supplier tolerances, equipment configuration, operating conditions and installation practices.

NOTE TO INSTALLER: This manual must be left with the equipment user.

USER: Please read all instructions in the manual and retain all manuals for future reference.

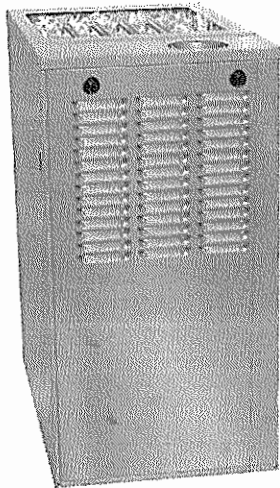

A200116

Representative drawing, some models may vary in appearance.



Use of the AHRI Certified TM Mark indicates a manufacturer's participation in the program. For verification of certification for individual products, go to www.ahrirectory.org.



ISO 9001
Quality

A200103

! WARNING

FIRE OR EXPLOSION HAZARD

Failure to follow safety warnings exactly could result in serious injury, death, or property damage.

Do not store or use gasoline or other flammable vapors and liquids in the vicinity of this or any other appliance.

WHAT TO DO IF YOU SMELL GAS

- Do not try to light any appliance.
- Do not touch any electrical switch; do not use any phone in your building.
- Leave the building immediately.
- Immediately call your gas supplier from a neighbor's phone. Follow the gas supplier's instructions.
- If you cannot reach your gas supplier, call the fire department.

Installation and service must be performed by a qualified installer, service agency or the gas supplier.

! WARNING

CARBON MONOXIDE POISONING HAZARD

Failure to follow this warning could result in personal injury and/or death.

Carbon Monoxide (CO) is a colorless, odorless, and tasteless poisonous gas that can be fatal when inhaled. Follow all installation, maintenance, and service instructions. See additional information below regarding the installation of a CO Alarm.

Most states in the USA and jurisdictions in Canada have laws that require the use of Carbon Monoxide (CO) alarms with fuel burning products. Examples of fuel burning products are furnaces, boilers, space heaters, generators, water heaters, stoves/ranges, clothes dryers, fireplaces, incinerators, automobiles, and other internal combustion engines. Even if there are no laws in your jurisdiction requiring a CO Alarm, it's highly recommended that whenever any fuel burning product is used in or around the home or business that the dwelling be equipped with a CO Alarm(s). The Consumer Product Safety Commission recommends the use of CO Alarm(s). The CO Alarm(s) must be installed, operated, and maintained according to the CO Alarm manufacturer's instructions. For more information about Carbon Monoxide, local laws, or to purchase a CO Alarm online, please visit the following website. <https://www.kidde.com>

! WARNING

ELECTRICAL OPERATION HAZARD

Failure to follow this warning could result in personal injury, death, or property damage.

Do not use this furnace if any part has been under water. A flood-damaged furnace is extremely dangerous. Attempts to use the furnace can result in fire or explosion. A qualified service agency should be contacted to inspect the furnace and to replace all gas controls, control system parts, electrical parts that have been wet or the furnace if deemed necessary.